

NOTE  
XXXX TYPE

- General Notes
- Elevations are shown from exterior unless otherwise noted
  - Anchor/wall fastener - Location, spacing and quantity to be determined per design pressure requirements by structural engineer and/or certified test drawings

|      |               |             |  |
|------|---------------|-------------|--|
| △    |               |             |  |
| △    |               |             |  |
| △    |               |             |  |
| △    |               |             |  |
| △    |               |             |  |
| △    |               |             |  |
| 0    | 2021. 00. 00. |             |  |
| REV. | v.3           | DESCRIPTION |  |

|              |               |       |  |
|--------------|---------------|-------|--|
| PROJECT      | -             |       |  |
| ITEM NO.     | -             |       |  |
| PRODUCT NAME | EWS75 TT 24mm |       |  |
| QTY          | 1             |       |  |
| VIEW         | EXTERIOR      |       |  |
| SCALE        | -             |       |  |
| DRAWING NO.  |               | ISSUE |  |

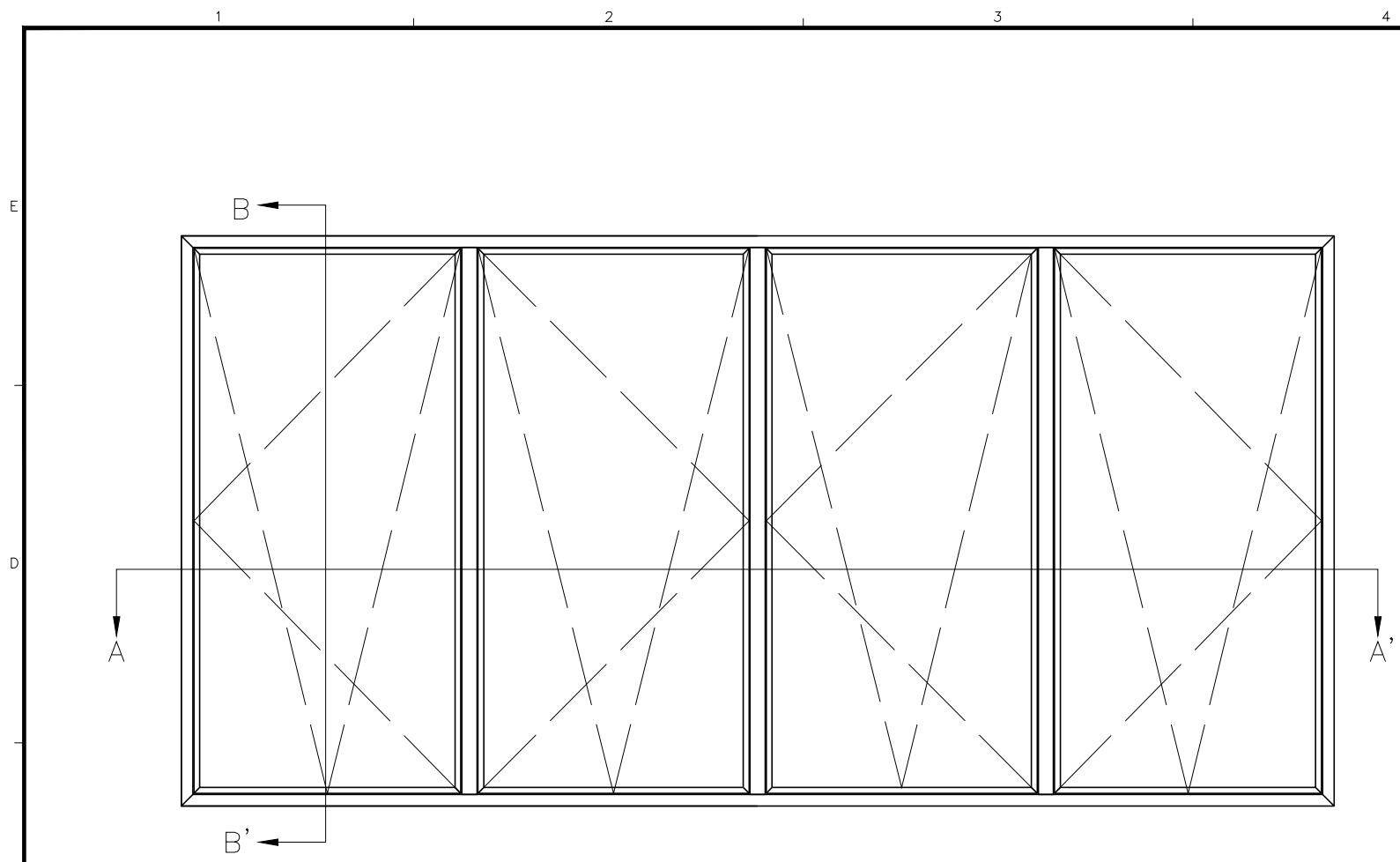

**ELEVATION**  
SCALE : 1/30

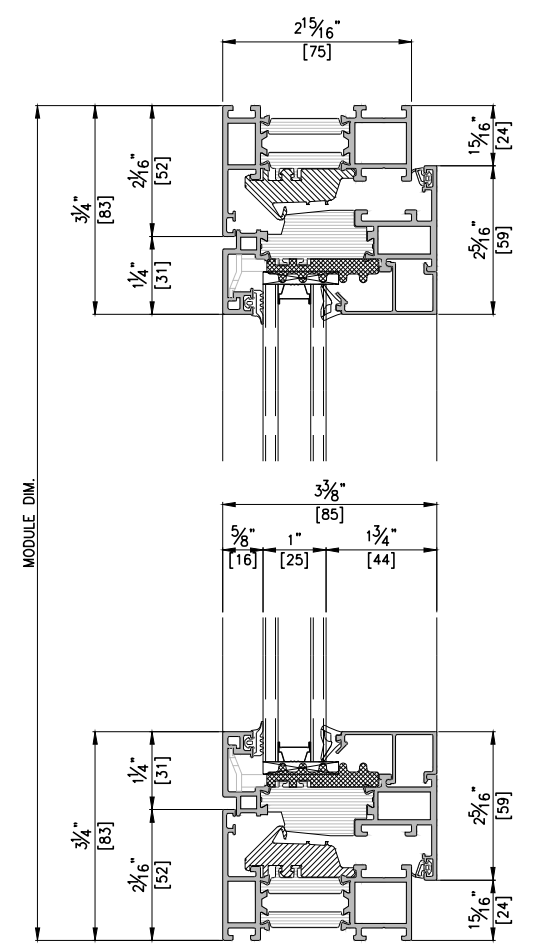

**VERTICAL SECTION DETAIL B-B'**  
SCALE : 1/3

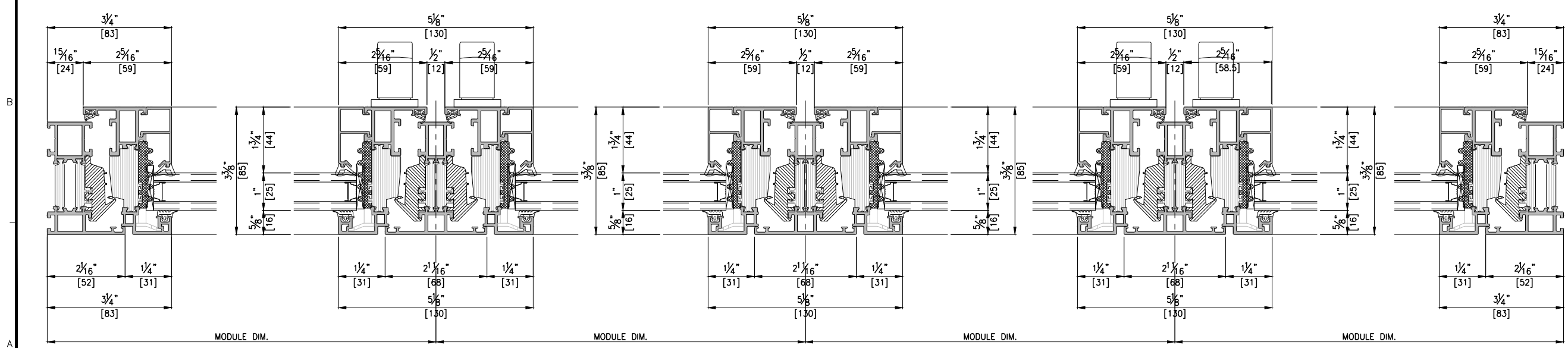

**HORIZONTAL SECTION DETAIL A-A'**  
SCALE : 1/3