

**ELEVATION**  
SCALE: 1/30

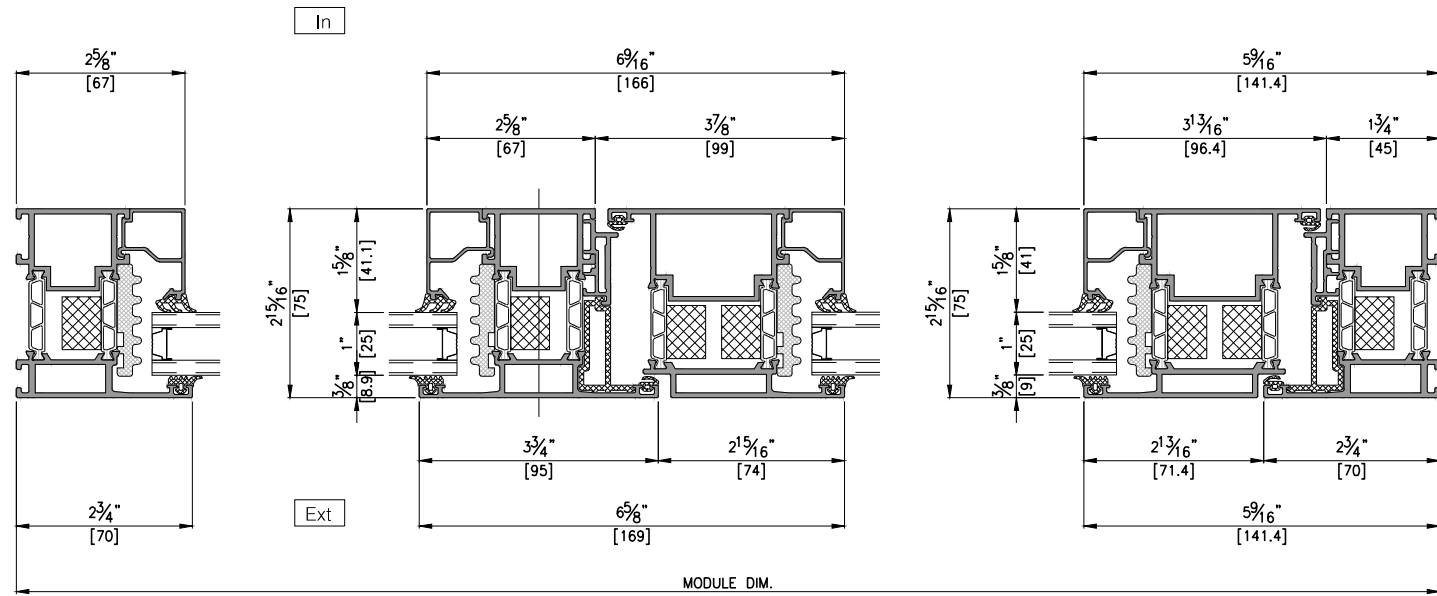

**HORIZONTAL SECTION DETAIL A-A'**  
SCALE: 1/3

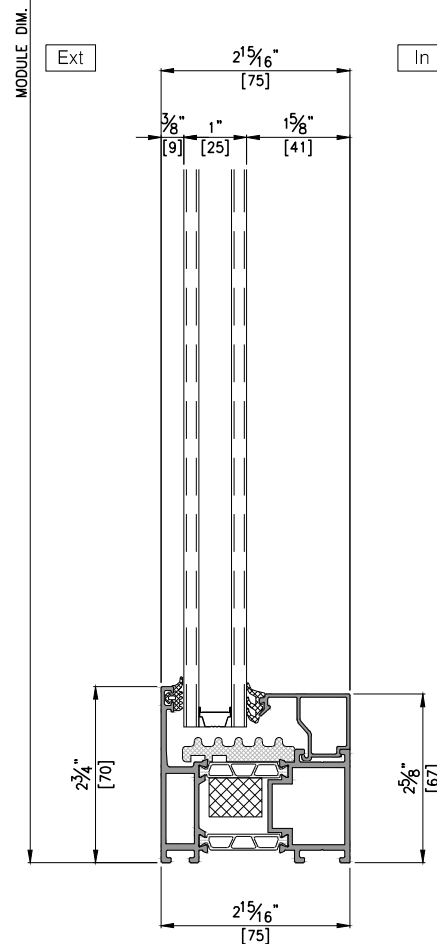
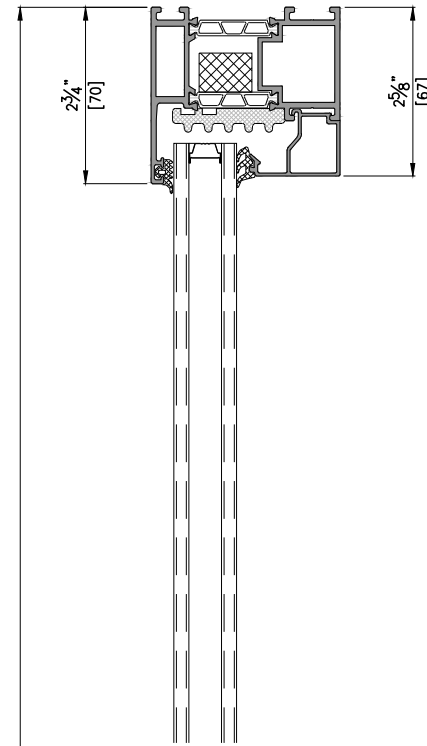

**VERTICAL SECTION DETAIL B-B'**  
SCALE: 1/3

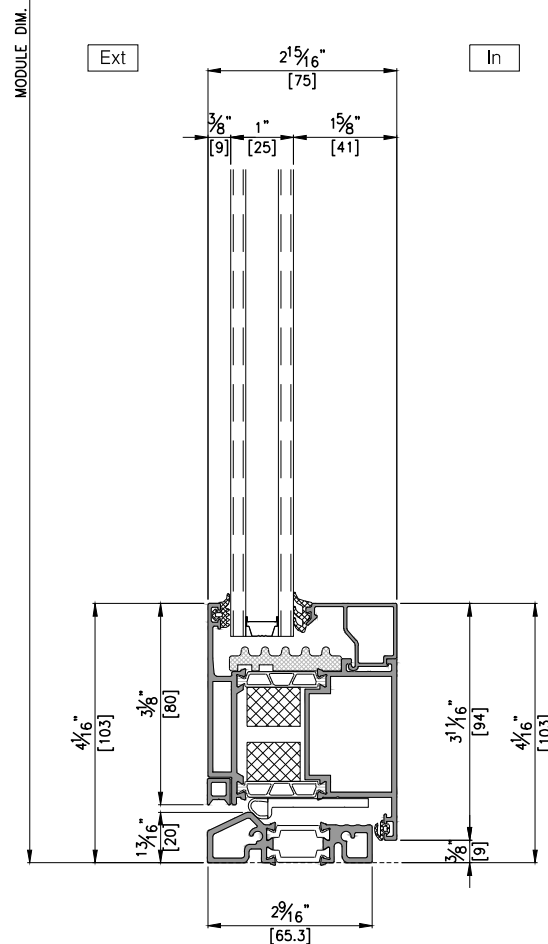
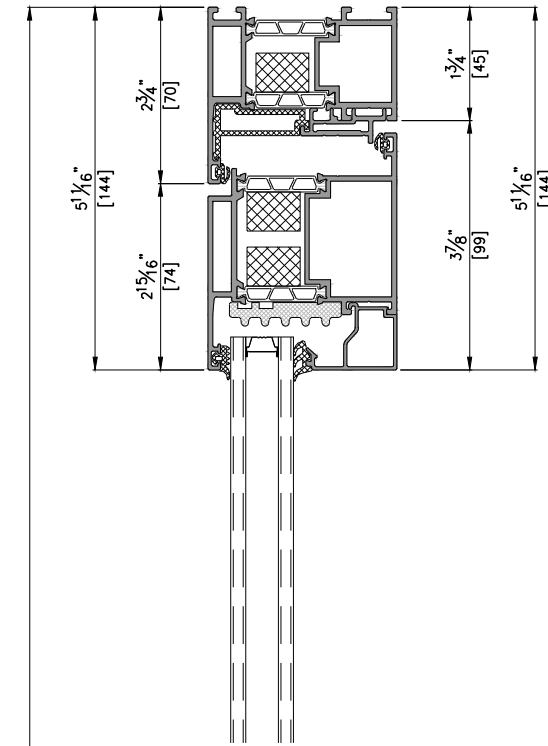

**VERTICAL SECTION DETAIL C-C'**  
SCALE: 1/3

NOTE  
OX TYPE

- General Notes
- Elevations are shown from exterior unless otherwise noted
  - Anchor/wall fastener - Location, spacing and quantity to be determined per design pressure requirements by structural engineer and/or certified test drawings

△			
△			
△			
△			
△			
0			
	2021. 00. 00.		
REV.	DESCRIPTION		
v.3			

PROJECT		-	
ITEM NO.		-	
PRODUCT NAME		EDS75 IW N/S ATTACH	
QTY	1		
VIEW	EXTERIOR		
SCALE	-		
DRAWING NO.		ISSUE	