

NOTE
XX TYPE

- General Notes
- Elevations are shown from exterior unless otherwise noted
 - Anchor/wall fastener – Location, spacing and quantity to be determined per design pressure requirements by structural engineer and/or certified test drawings

△			
△			
△			
△			
○			
	2021. 00. 00.		
	DESCRIPTION		
REV.	v3		

PROJECT
-

ITEM NO.
-

PRODUCT NAME
EDS75 OW
NO SILL

QTY
1

VIEW
EXTERIOR

SCALE
-

DRAWING NO. ISSUE

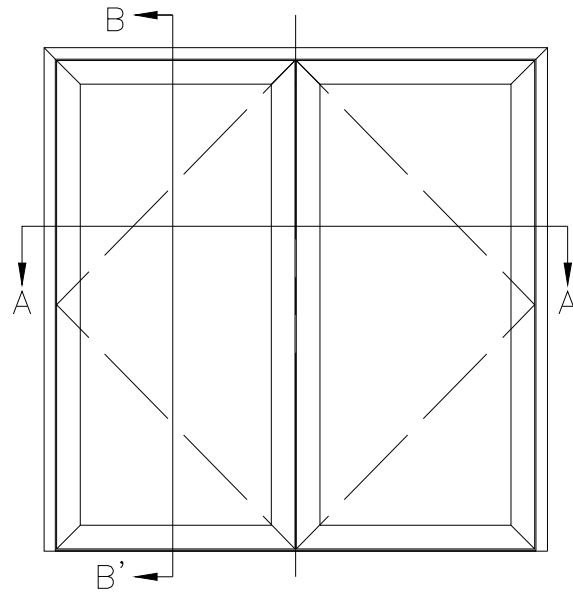

ELEVATION
SCALE: 1/30

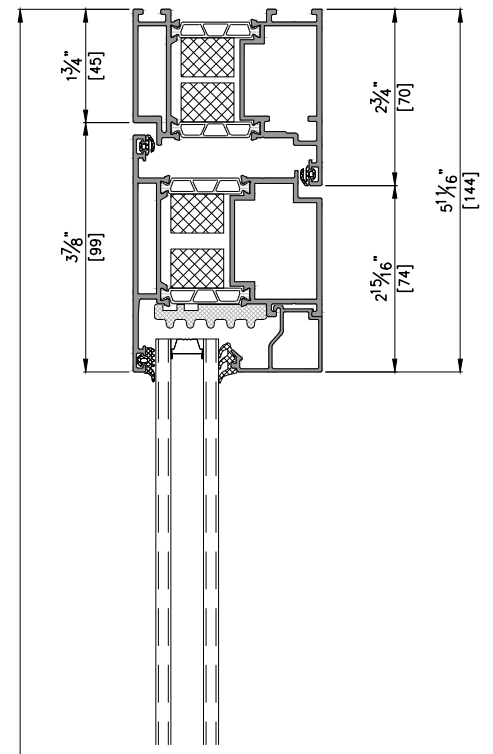

MODULE DIM.

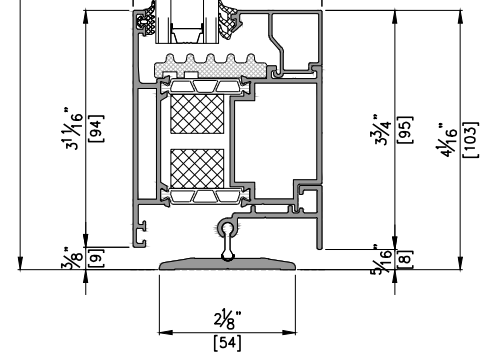
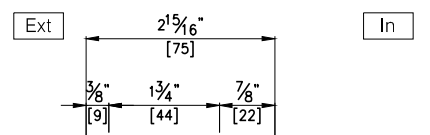

VERTICAL SECTION DETAIL B-B'
SCALE: 1/3

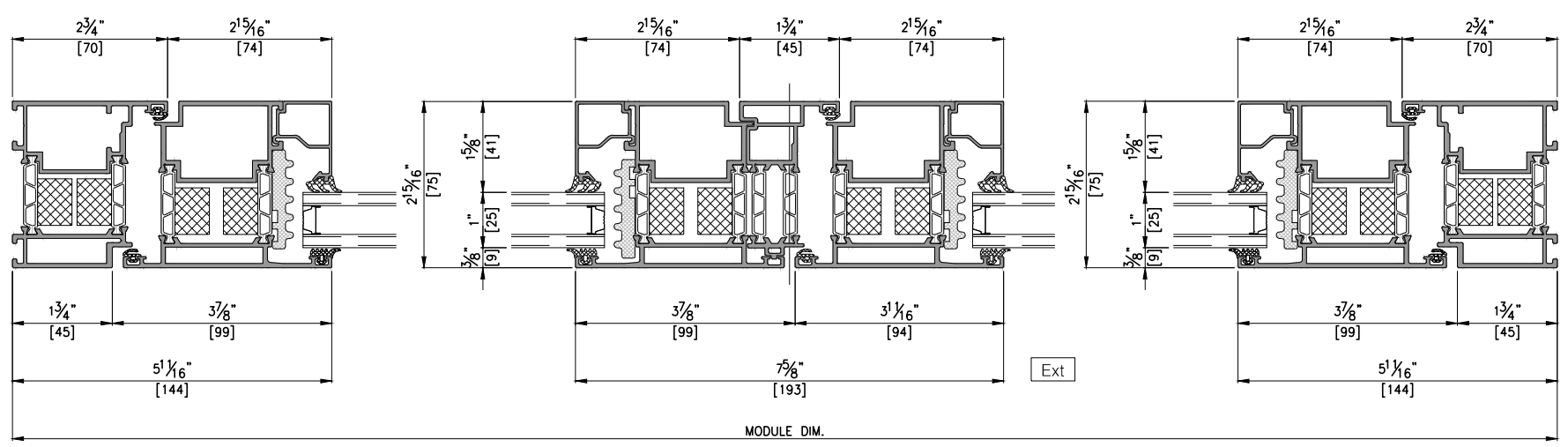

HORIZONTAL SECTION DETAIL A-A'
SCALE: 1/3