





NOTE
X TYPE

- General Notes
- Elevations are shown from exterior unless otherwise noted
 - Anchor/wall fastener – Location, spacing and quantity to be determined per design pressure requirements by structural engineer and/or certified test drawings

	
	
	
	
	2021. 00. 00.
REV.	DESCRIPTION
v.3	

PROJECT
-

ITEM NO.
-

PRODUCT NAME
EDS95 OW N/S
ATTACH

QTY
1

VIEW
EXTERIOR

SCALE
-

DRAWING NO. ISSUE

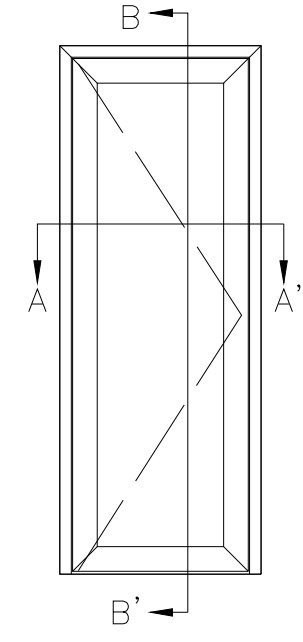

ELEVATION
SCALE : 1/30

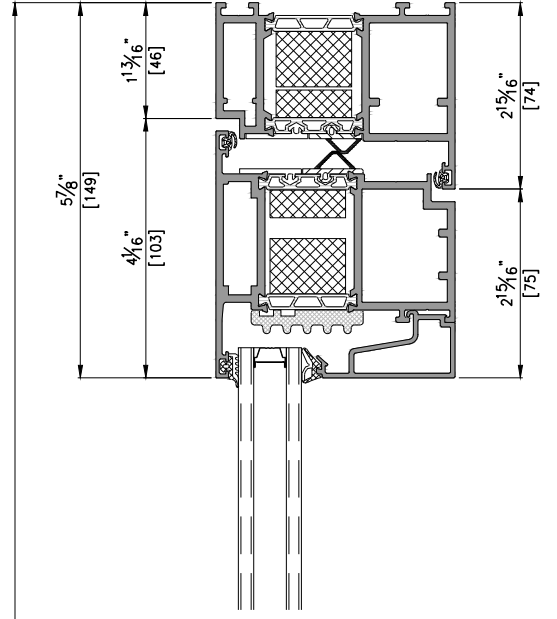

MODULE DIM.

Ext In

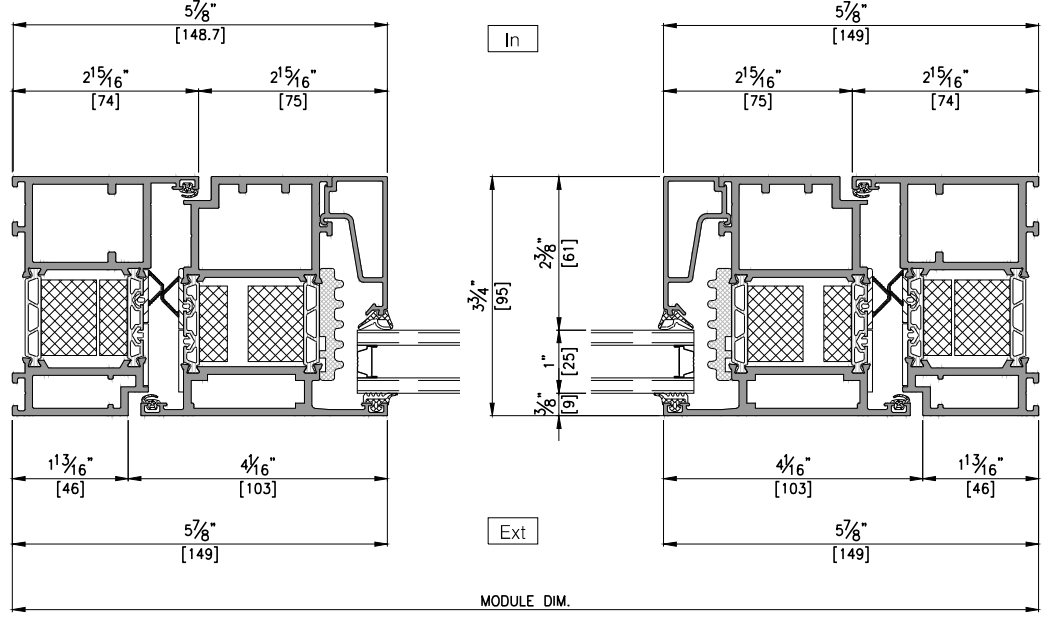
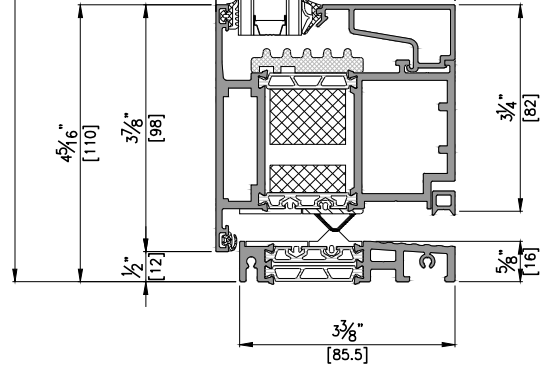

HORIZONTAL SECTION DETAIL A-A'
SCALE : 1/3

VERTICAL SECTION DETAIL B-B'
SCALE : 1/3