

**ELEVATION**  
SCALE: 1/30

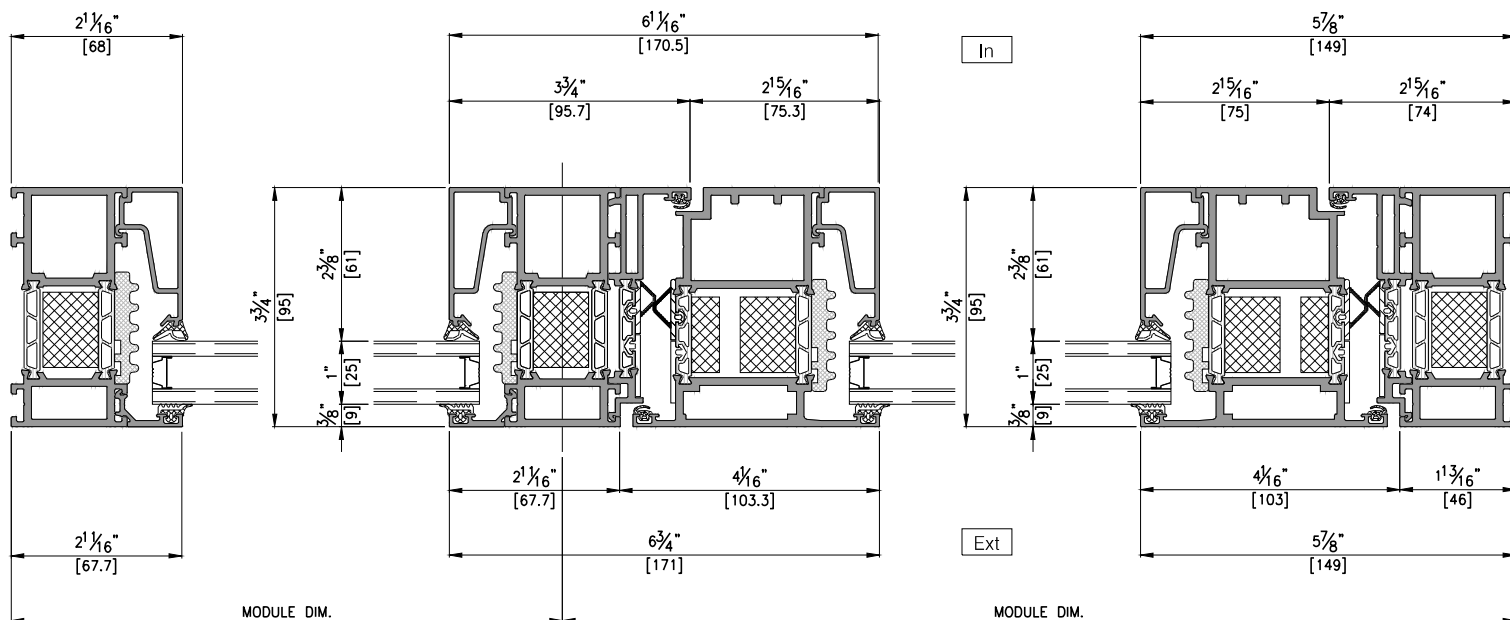

**HORIZONTAL SECTION DETAIL A-A'**  
SCALE: 1/3

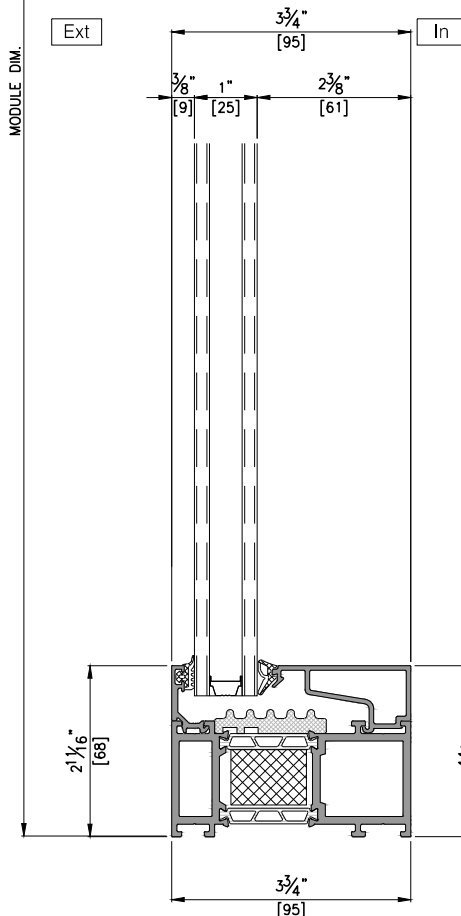
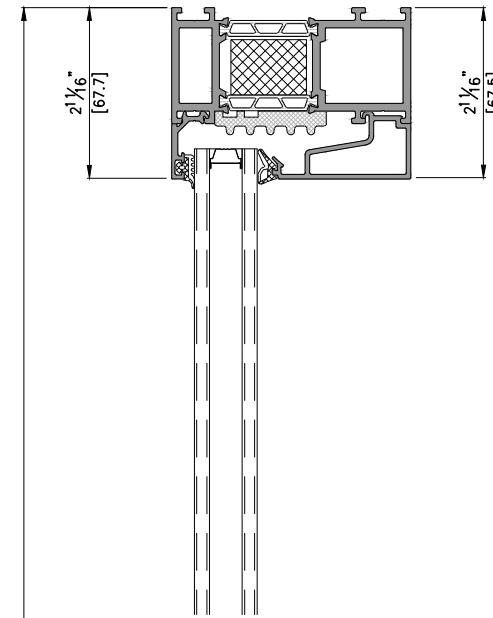

**VERTICAL SECTION DETAIL B-B'**  
SCALE: 1/3

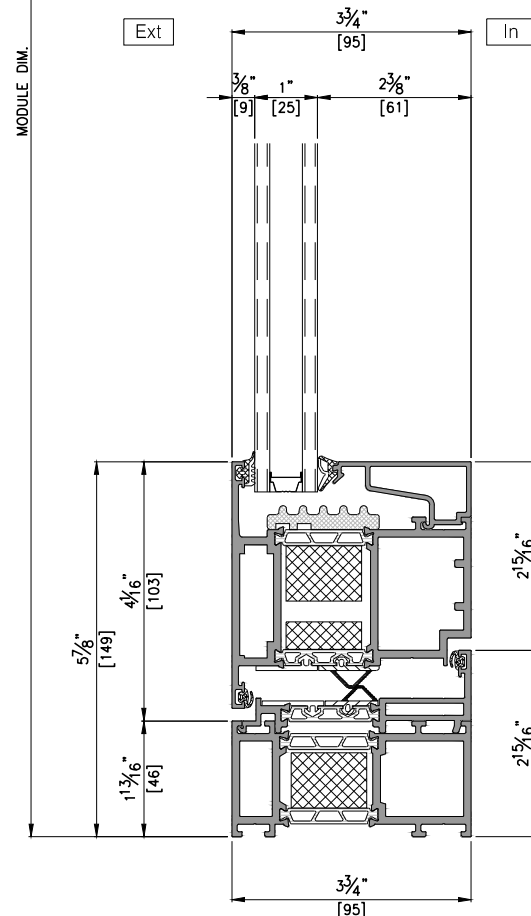
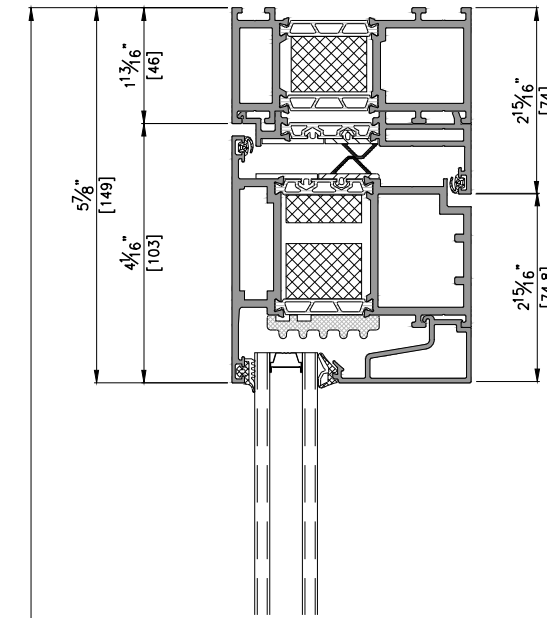

**VERTICAL SECTION DETAIL C-C'**  
SCALE: 1/3

NOTE  
OX TYPE

- General Notes
- Elevations are shown from exterior unless otherwise noted
  - Anchor/wall fastener - Location, spacing and quantity to be determined per design pressure requirements by structural engineer and/or certified test drawings

| △    |               |
|------|---------------|
| △    |               |
| △    |               |
| △    |               |
| △    |               |
| 0    |               |
|      | 2021. 00. 00. |
| REV. | DESCRIPTION   |
| v.3  |               |

|              |                        |
|--------------|------------------------|
| PROJECT      | -                      |
| ITEM NO.     | -                      |
| PRODUCT NAME | EDS95 OW W/S WITH SILL |
| QTY          | 1                      |
| VIEW         | EXTERIOR               |
| SCALE        | -                      |
| DRAWING NO.  |                        |
| ISSUE        |                        |