

# EAGON WINDOWS & DOORS CO., LTD.

## COMPUTER SIMULATION REPORT

### SCOPE OF WORK

ESS 70 MT SD SLIDING PATIO DOOR - NFRC 100/200/500

### REPORT NUMBER

L1411.02-116-45 R0 R0

### TEST DATE

07/08/20

### ISSUE DATE

09/03/21

### RECORD RETENTION END DATE

07/08/25

### PAGES

87

### DOCUMENT CONTROL NUMBER

RT-R-AMER-Test-4044 (01/16/19)

©2017 INTERTEK

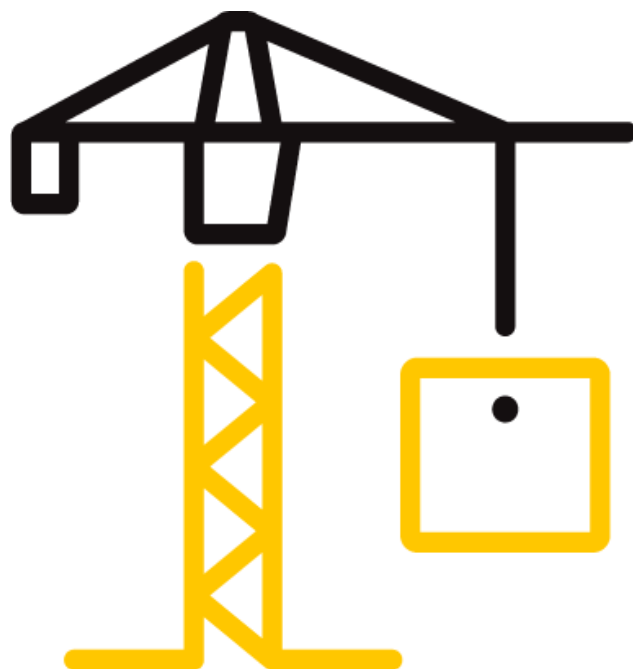



Total Quality. Assured.

130 Derry Court  
York, Pennsylvania 17406

Telephone: 717-764-7700  
Facsimile: 717-764-4129  
www.intertek.com/building

**TEST REPORT FOR EAGON WINDOWS & DOORS CO., LTD.**

Report No: L1411.02-116-45 R0 R0

Date: 09/03/21

**REPORT ISSUED TO**

**EAGON WINDOWS & DOORS CO., LTD.**

91 Yeomjeon-ro

Incheon

Korea, 22107

**SECTION 1**

**SUMMARY**

**SERIES/MODEL: ESS 70 MT SD Sliding Patio Door**

Architectural Testing, Inc. (an Intertek company) dba Intertek Building & Construction (B&C) was contracted to perform U-Factor, Solar Heat Gain Coefficient, Visible Transmittance and Condensation Resistance simulations in accordance with the National Fenestration Rating Council (NFRC).

This report does not constitute certification of this product nor an opinion or endorsement by this laboratory. Intertek B&C will service this report for the entire test record retention period. The test record retention period ends five years after the test date. Test records, such as detailed drawings, datasheets, representative samples of test specimens, or other pertinent project documentation, will be retained for the entire test record retention period.

FOR INTERTEK B&C:

**COMPLETED BY:** Eric S. Leitner  
Manager - Thermal  
**TITLE:** Testing & Simulations  
**SIGNATURE:**  
**DATE:** 09/03/21

**REVIEWED BY:** Allison M. Ford  
**TITLE:** Simulation Technician  
**SIGNATURE:**  
**DATE:** 09/03/21

ESL:esl

---

This report is for the exclusive use of Intertek's Client and is provided pursuant to the agreement between Intertek and its Client. Intertek's responsibility and liability are limited to the terms and conditions of the agreement. Intertek assumes no liability to any party, other than to the Client in accordance with the agreement, for any loss, expense or damage occasioned by the use of this report. Only the Client is authorized to permit copying or distribution of this report and then only in its entirety. Any use of the Intertek name or one of its marks for the sale or advertisement of the tested material, product or service must first be approved in writing by Intertek. The observations and test results in this report are relevant only to the sample(s) tested. This report by itself does not imply that the material, product, or service is or has ever been under an Intertek certification program.

## TEST REPORT FOR EAGON WINDOWS & DOORS CO., LTD.

Report No: L1411.02-116-45 R0 R0

Date: 09/03/21

### SECTION 2

#### TEST METHODS

The products were evaluated in accordance with the following:

***ANSI/NFRC 100-2020, Procedure for Determining Fenestration Product U-Factors***

***ANSI/NFRC 200-2020, Procedure for Determining Fenestration Product Solar Heat Gain Coefficient and Visible Transmittance at Normal Incidence***

***NFRC 500-2017, Procedure for Determining Fenestration Product Condensation Resistance Values***

*\*Condensation Resistance results obtained from this procedure are for controlled laboratory conditions and do not include the effects of air movement through the specimen, solar radiation, and the thermal bridging that may occur due to the specific design and construction of the fenestration system opening.*

Ratings values included in this report are for submittals to an NFRC-licensed IA and are not meant to be used directly for labeling purposes. Only those values identified on a valid Certificate of Authorization (CA) by an NFRC accredited Inspection Agency (IA) are to be used for labeling purposes. The ratings values were rounded in accordance with NFRC 601, NFRC Unit and Measurement Policy.

Intertek B&C is an NFRC accredited simulation laboratory and all simulations were conducted in full compliance with NFRC approved procedures and specifications. The values included in this report are not considered in compliance with ANSI/NFRC 100, ANSI/NFRC 200, and/or NFRC 500 unless the associated validation test requirements have been satisfied, as applicable.

**TEST REPORT FOR EAGON WINDOWS & DOORS CO., LTD.**

Report No: L1411.02-116-45 R0 R0

Date: 09/03/21

**SECTION 3**

**TEST PROCEDURE**

The total product, including specific frame, spacer, and glass details, was modeled using NFRC approved software.

<b>FRAME AND EDGE MODELING</b>	THERM 7.4.4
<b>CENTER-OF-GLASS MODELING</b>	WINDOW 7.4.14
<b>TOTAL PRODUCT CALCULATIONS</b>	WINDOW 7.4.14
<b>SPECTRAL DATA LIBRARY</b>	IGDB 78.0

**Modeling Assumptions / Technical Interpretations**

Any modeling assumptions and technical interpretations required to model this product are listed below.

- 1) To prevent air infiltration, tape was applied to all interior sash crack locations.

**SECTION 4**

**SIMULATION SPECIMEN DESCRIPTION**

<b>SERIES/MODEL</b>	ESS 70 MT SD Sliding Patio Door
<b>PRODUCT TYPE</b>	Sliding Glass Door, Sliding Glass Door (XX or OX)
<b>FRAME MATERIAL</b>	AT - Aluminum w/ Thermal Breaks - All Members
<b>SASH MATERIAL</b>	AT - Aluminum w/ Thermal Breaks - All Members
<b>STANDARD SIZE</b>	2000mm x 2000mm

**TEST REPORT FOR EAGON WINDOWS & DOORS CO., LTD.**

Report No: L1411.02-116-45 R0 R0

Date: 09/03/21

**SECTION 4 (Continued)**

**SIMULATION SPECIMEN DESCRIPTION**

<b>SPACER OPTIONS</b>			
<b>TYPE</b>	<b>PRIMARY SEAL</b>	<b>SECONDARY SEAL</b>	<b>CODE</b>
Cardinal Endur Spacer	Royal PIB	Silicone	SS-D
Technoform TGI Spacer	PIB	Silicone	TS-D
Quanex Premium Super Spacer S2	Butyl Rubber	None	ZF-S
Allmetal LPX Spacer	Silicone	Silicone	A1-D

<b>GRID OPTIONS</b>		
<b>GRID SIZE</b>	<b>GRID TYPE</b>	<b>GRID PATTERN</b>
None	-	-

<b>REINFORCEMENT OPTIONS</b>	
<b>LOCATION</b>	<b>MATERIAL</b>
None	-

<b>GAS FILLING TECHNIQUE</b>	
<b>FILL TYPE</b>	<b>METHOD</b>
90% Argon	Single probe

<b>EDGE-OF-GLASS CONSTRUCTION</b>	
<b>INTERIOR CONDITION</b>	EPDM gasket between glazing bead and glass
<b>EXTERIOR CONDITION</b>	EPDM gasket between frame and glass

<b>WEATHERSTRIPPING</b>		
<b>TYPE</b>	<b>QUANTITY</b>	<b>LOCATION</b>
Finpile	2 rows	Frame perimeter

<b>FRAME/SASH MATERIALS FINISH</b>	
<b>INTERIOR</b>	Painted aluminum
<b>EXTERIOR</b>	Painted aluminum

<b>VALIDATION MATRIX*</b>	
<b>PRODUCT LINE</b>	<b>REPORT NUMBER</b>
None	-

*\*These products are part of a validation matrix. Only one is required for validation testing.*

**TEST REPORT FOR EAGON WINDOWS & DOORS CO., LTD.**

Report No: L1411.02-116-45 R0 R0

Date: 09/03/21

**SECTION 5**

**SPECIALTY PRODUCTS TABLE**

The specialty products method allows the manufacturer to determine the overall product SHGC and VT for any glazing option. The center of glass SHGC and/or VT must be determined using WINDOW 7.4.14. The method calculates overall product SHGC and VT indexed on center of glass properties. All values used in the calculations are truncated to six decimal place precision.

<i>ESS 70 SD MT</i>	No Dividers	Dividers < 1	Dividers > 1
SHGC0	0.007525	0.010747	0.013755
SHGC1	0.795287	0.700311	0.611652
VT0	0.000000	0.000000	0.000000
VT1	0.787762	0.689564	0.597898

<i>ESS 70 SD MT 'A Type'</i>	No Dividers	Dividers < 1	Dividers > 1
SHGC0	0.008976	0.012176	0.015162
SHGC1	0.786656	0.692324	0.604310
VT0	0.000000	0.000000	0.000000
VT1	0.777680	0.680148	0.589148

$$SHGC = SHGC0 + SHGCc (SHGC1 - SHGC0)$$

$$VT = VT0 + VTc (VT1 - VT0)$$

## TEST REPORT FOR EAGON WINDOWS & DOORS CO., LTD.

Report No: L1411.02-116-45 R0 R0

Date: 09/03/21

### SECTION 6

### SIMULATION RESULTS

TOTAL PRODUCT CALCULATIONS (ESS 70 MT SD Sliding Patio Door)												
Option Number	Pane Thickness 1 (in)	Gap Width 1 (in)	Pane Thickness 2 (in)	Gap Width 2 (in)	Pane Thickness 3 (in)	Gap Width 3 (in)	Pane Thickness 4 (in)	Gap Fill	Low-e (Surface #)	Tint	Spacer	Grid Type
	U-Factor (Btu/Hr-Ft2-F)			Solar Heat Gain Coefficient (SHGC) Grids (None / <1 / >=1)				Visible Transmittance (VT) Grids (None / <1 / >=1)		Condensation Resistance (CR)		
1	ESS 70 SD MT: E366 / arg90 / i89 (6mm/6mm) - 25mm IG											
	0.224	0.500	0.223					ARG90	0.020(#2) / 0.149(#4)	CL	SS-D	N
	U-Factor 0.32			SHGC(N) 0.22				VT(N) 0.48		CR 45		
2	ESS 70 SD MT: E270 / arg90 / i89 (6mm/6mm) - 25mm IG											
	0.224	0.500	0.223					ARG90	0.035(#2) / 0.149(#4)	CL	SS-D	N
	U-Factor 0.32			SHGC(N) 0.28				VT(N) 0.52		CR 45		
3	ESS 70 SD MT: E180 / arg90 / i89 (6mm/6mm) - 25mm IG											
	0.223	0.500	0.223					ARG90	0.068(#2) / 0.149(#4)	CL	SS-D	N
	U-Factor 0.33			SHGC(N) 0.46				VT(N) 0.59		CR 44		
4	ESS 70 SD MT: E366 / air / i89 (6mm/6mm) - 25mm IG											
	0.224	0.500	0.223					AIR	0.020(#2) / 0.149(#4)	CL	SS-D	N
	U-Factor 0.34			SHGC(N) 0.22				VT(N) 0.48		CR 42		
5	ESS 70 SD MT: E270 / air / i89 (6mm/6mm) - 25mm IG											
	0.224	0.500	0.223					AIR	0.035(#2) / 0.149(#4)	CL	SS-D	N
	U-Factor 0.34			SHGC(N) 0.28				VT(N) 0.52		CR 42		
6	ESS 70 SD MT: E366 / arg90 / clr (6mm/6mm) - 25mm IG											
	0.224	0.500	0.224					ARG90	0.020(#2)	CL	SS-D	N
	U-Factor 0.36			SHGC(N) 0.22				VT(N) 0.50		CR 51		
7	ESS 70 SD MT: E272 / arg90 / clr (6mm/6mm) - 25mm IG											
	0.224	0.500	0.224					ARG90	0.042(#2)	CL	SS-D	N
	U-Factor 0.36			SHGC(N) 0.32				VT(N) 0.55		CR 51		
8	ESS 70 SD MT: SB60 / arg90 / clr (6mm/6mm) - 25mm IG											
	0.223	0.500	0.223					ARG90	0.035(#2)	CL	TS-D	N
	U-Factor 0.36			SHGC(N) 0.31				VT(N) 0.55		CR 51		
9	ESS 70 SD MT: SB70 / arg90 / clr (6mm/6mm) - 25mm IG											
	0.223	0.500	0.223					ARG90	0.018(#2)	CL	TS-D	N
	U-Factor 0.36			SHGC(N) 0.22				VT(N) 0.51		CR 51		
10	ESS 70 SD MT: SNX 62/27 / arg90 / clr (6mm/6mm) - 25mm IG											
	0.221	0.500	0.221					ARG90	0.020(#2)	CL	ZF-S	N
	U-Factor 0.35			SHGC(N) 0.21				VT(N) 0.49		CR 52		

## TEST REPORT FOR EAGON WINDOWS & DOORS CO., LTD.

Report No: L1411.02-116-45 R0 R0

Date: 09/03/21

### SECTION 6 (Continued)

### SIMULATION RESULTS

TOTAL PRODUCT CALCULATIONS (ESS 70 MT SD Sliding Patio Door)												
Option Number	Pane Thickness 1 (in)	Gap Width 1 (in)	Pane Thickness 2 (in)	Gap Width 2 (in)	Pane Thickness 3 (in)	Gap Width 3 (in)	Pane Thickness 4 (in)	Gap Fill	Low-e (Surface #)	Tint	Spacer	Grid Type
	U-Factor (Btu/Hr-Ft <sup>2</sup> -F)			Solar Heat Gain Coefficient (SHGC) Grids (None / <1 / >=1)				Visible Transmittance (VT) Grids (None / <1 / >=1)		Condensation Resistance (CR)		
11	ESS 70 SD MT: SNX 62/27 / air / clr (6mm/6mm) - 25mm IG											
	0.221	0.500	0.221					AIR	0.020(#2)	CL	ZF-S	N
	U-Factor 0.39			SHGC(N) 0.22				VT(N) 0.49		CR 52		
12	ESS 70 SD MT: SN68 / arg90 / clr (6mm/6mm) - 25mm IG											
	0.221	0.500	0.221					ARG90	0.039(#2)	CL	ZF-S	N
	U-Factor 0.36			SHGC(N) 0.30				VT(N) 0.54		CR 52		
13	ESS 70 SD MT: SNX 62/27 / arg90 / IS-20 (6mm/6mm) - 25mm IG											
	0.221	0.500	0.221					ARG90	0.020(#2) / 0.198(#4)	CL	ZF-S	N
	U-Factor 0.32			SHGC(N) 0.21				VT(N) 0.47		CR 47		
14	ESS 70 SD MT: SNX 62/27 / air / IS-20 (6mm/6mm) - 25mm IG											
	0.221	0.500	0.221					AIR	0.020(#2) / 0.198(#4)	CL	ZF-S	N
	U-Factor 0.35			SHGC(N) 0.21				VT(N) 0.47		CR 44		
15	ESS 70 SD MT: SN68 / air / clr (6mm/6mm) - 25mm IG											
	0.221	0.500	0.221					AIR	0.039(#2)	CL	ZF-S	N
	U-Factor 0.39			SHGC(N) 0.30				VT(N) 0.54		CR 51		
16	ESS 70 SD MT: SN68 / arg90 / IS-20 (6mm/6mm) - 25mm IG											
	0.221	0.500	0.221					ARG90	0.039(#2) / 0.198(#4)	CL	ZF-S	N
	U-Factor 0.32			SHGC(N) 0.29				VT(N) 0.52		CR 46		
17	ESS 70 SD MT: SNX 51/23 / air / clr (6mm/6mm) - 25mm IG											
	0.221	0.500	0.221					AIR	0.021(#2)	CL	A1-D	N
	U-Factor 0.41			SHGC(N) 0.19				VT(N) 0.40		CR 46		
18	ESS 70 SD MT: SNX 51/23 / arg90 / clr (6mm/6mm) - 25mm IG											
	0.221	0.500	0.221					ARG90	0.021(#2)	CL	A1-D	N
	U-Factor 0.37			SHGC(N) 0.19				VT(N) 0.40		CR 48		
19	ESS 70 SD MT: SNX 51/23 / air / IS-20 (6mm/6mm) - 25mm IG											
	0.221	0.500	0.221					AIR	0.021(#2) / 0.198(#4)	CL	A1-D	N
	U-Factor 0.36			SHGC(N) 0.18				VT(N) 0.39		CR 37		
20	ESS 70 SD MT: SNX 51/23 / arg90 / IS-20 (6mm/6mm) - 25mm IG											
	0.221	0.500	0.221					ARG90	0.021(#2) / 0.198(#4)	CL	A1-D	N
	U-Factor 0.34			SHGC(N) 0.18				VT(N) 0.39		CR 40		



## TEST REPORT FOR EAGON WINDOWS & DOORS CO., LTD.

Report No: L1411.02-116-45 R0 R0

Date: 09/03/21

### SECTION 6 (Continued)

### SIMULATION RESULTS

TOTAL PRODUCT CALCULATIONS (ESS 70 MT SD Sliding Patio Door)												
Option Number	Pane Thickness 1 (in)	Gap Width 1 (in)	Pane Thickness 2 (in)	Gap Width 2 (in)	Pane Thickness 3 (in)	Gap Width 3 (in)	Pane Thickness 4 (in)	Gap Fill	Low-e (Surface #)	Tint	Spacer	Grid Type
	U-Factor (Btu/Hr-Ft2-F)			Solar Heat Gain Coefficient (SHGC) Grids (None / <1 / >=1)				Visible Transmittance (VT) Grids (None / <1 / >=1)		Condensation Resistance (CR)		
21	ESS 70 SD MT 'A Type': E366 / arg90 / i89 (6mm/6mm) - 25mm IG											
	0.224	0.500	0.223					ARG90	0.020(#2) / 0.149(#4)	CL	SS-D	N
	U-Factor 0.33			SHGC(N) 0.21				VT(N) 0.48		CR 44		
22	ESS 70 SD MT 'A Type': E270 / arg90 / i89 (6mm/6mm) - 25mm IG											
	0.224	0.500	0.223					ARG90	0.035(#2) / 0.149(#4)	CL	SS-D	N
	U-Factor 0.33			SHGC(N) 0.28				VT(N) 0.51		CR 44		
23	ESS 70 SD MT 'A Type': E180 / arg90 / i89 (6mm/6mm) - 25mm IG											
	0.223	0.500	0.223					ARG90	0.068(#2) / 0.149(#4)	CL	SS-D	N
	U-Factor 0.34			SHGC(N) 0.46				VT(N) 0.58		CR 43		
24	ESS 70 SD MT 'A Type': E366 / air / i89 (6mm/6mm) - 25mm IG											
	0.224	0.500	0.223					AIR	0.020(#2) / 0.149(#4)	CL	SS-D	N
	U-Factor 0.35			SHGC(N) 0.22				VT(N) 0.48		CR 41		
25	ESS 70 SD MT 'A Type': E270 / air / i89 (6mm/6mm) - 25mm IG											
	0.224	0.500	0.223					AIR	0.035(#2) / 0.149(#4)	CL	SS-D	N
	U-Factor 0.35			SHGC(N) 0.28				VT(N) 0.51		CR 41		
26	ESS 70 SD MT 'A Type': E366 / arg90 / clr (6mm/6mm) - 25mm IG											
	0.224	0.500	0.224					ARG90	0.020(#2)	CL	SS-D	N
	U-Factor 0.37			SHGC(N) 0.22				VT(N) 0.49		CR 50		
27	ESS 70 SD MT 'A Type': E272 / arg90 / clr (6mm/6mm) - 25mm IG											
	0.224	0.500	0.224					ARG90	0.042(#2)	CL	SS-D	N
	U-Factor 0.37			SHGC(N) 0.32				VT(N) 0.54		CR 50		
28	ESS 70 SD MT 'A Type': SB60 / arg90 / clr (6mm/6mm) - 25mm IG											
	0.223	0.500	0.223					ARG90	0.035(#2)	CL	TS-D	N
	U-Factor 0.37			SHGC(N) 0.31				VT(N) 0.55		CR 49		
29	ESS 70 SD MT 'A Type': SB70 / arg90 / clr (6mm/6mm) - 25mm IG											
	0.223	0.500	0.223					ARG90	0.018(#2)	CL	TS-D	N
	U-Factor 0.37			SHGC(N) 0.22				VT(N) 0.50		CR 49		
30	ESS 70 SD MT 'A Type': SNX 62/27 / arg90 / clr (6mm/6mm) - 25mm IG											
	0.221	0.500	0.221					ARG90	0.020(#2)	CL	ZF-S	N
	U-Factor 0.36			SHGC(N) 0.21				VT(N) 0.48		CR 50		

## TEST REPORT FOR EAGON WINDOWS & DOORS CO., LTD.

Report No: L1411.02-116-45 R0 R0

Date: 09/03/21

### SECTION 6 (Continued)

### SIMULATION RESULTS

TOTAL PRODUCT CALCULATIONS (ESS 70 MT SD Sliding Patio Door)												
Option Number	Pane Thickness 1 (in)	Gap Width 1 (in)	Pane Thickness 2 (in)	Gap Width 2 (in)	Pane Thickness 3 (in)	Gap Width 3 (in)	Pane Thickness 4 (in)	Gap Fill	Low-e (Surface #)	Tint	Spacer	Grid Type
	U-Factor (Btu/Hr-Ft2-F)			Solar Heat Gain Coefficient (SHGC) Grids (None / <1 / >=1)				Visible Transmittance (VT) Grids (None / <1 / >=1)		Condensation Resistance (CR)		
31	ESS 70 SD MT 'A Type': SNX 62/27 / air / clr (6mm/6mm) - 25mm IG											
	0.221	0.500	0.221					AIR	0.020(#2)	CL	ZF-S	N
	U-Factor 0.40			SHGC(N) 0.22				VT(N) 0.48		CR 50		
32	ESS 70 SD MT 'A Type': SN68 / arg90 / clr (6mm/6mm) - 25mm IG											
	0.221	0.500	0.221					ARG90	0.039(#2)	CL	ZF-S	N
	U-Factor 0.37			SHGC(N) 0.30				VT(N) 0.53		CR 50		
33	ESS 70 SD MT 'A Type': SNX 62/27 / arg90 / IS-20 (6mm/6mm) - 25mm IG											
	0.221	0.500	0.221					ARG90	0.020(#2) / 0.198(#4)	CL	ZF-S	N
	U-Factor 0.33			SHGC(N) 0.21				VT(N) 0.46		CR 46		
34	ESS 70 SD MT 'A Type': SNX 62/27 / air / IS-20 (6mm/6mm) - 25mm IG											
	0.221	0.500	0.221					AIR	0.020(#2) / 0.198(#4)	CL	ZF-S	N
	U-Factor 0.35			SHGC(N) 0.21				VT(N) 0.46		CR 43		
35	ESS 70 SD MT 'A Type': SN68 / air / clr (6mm/6mm) - 25mm IG											
	0.221	0.500	0.221					AIR	0.039(#2)	CL	ZF-S	N
	U-Factor 0.40			SHGC(N) 0.30				VT(N) 0.53		CR 50		
36	ESS 70 SD MT 'A Type': SN68 / arg90 / IS-20 (6mm/6mm) - 25mm IG											
	0.221	0.500	0.221					ARG90	0.039(#2) / 0.198(#4)	CL	ZF-S	N
	U-Factor 0.33			SHGC(N) 0.29				VT(N) 0.51		CR 45		
37	ESS 70 SD MT 'A Type': SNX 51/23 / air / clr (6mm/6mm) - 25mm IG											
	0.221	0.500	0.221					AIR	0.021(#2)	CL	A1-D	N
	U-Factor 0.41			SHGC(N) 0.19				VT(N) 0.40		CR 45		
38	ESS 70 SD MT 'A Type': SNX 51/23 / arg90 / clr (6mm/6mm) - 25mm IG											
	0.221	0.500	0.221					ARG90	0.021(#2)	CL	A1-D	N
	U-Factor 0.38			SHGC(N) 0.18				VT(N) 0.40		CR 48		
39	ESS 70 SD MT 'A Type': SNX 51/23 / air / IS-20 (6mm/6mm) - 25mm IG											
	0.221	0.500	0.221					AIR	0.021(#2) / 0.198(#4)	CL	A1-D	N
	U-Factor 0.37			SHGC(N) 0.18				VT(N) 0.38		CR 37		
40	ESS 70 SD MT 'A Type': SNX 51/23 / arg90 / IS-20 (6mm/6mm) - 25mm IG											
	0.221	0.500	0.221					ARG90	0.021(#2) / 0.198(#4)	CL	A1-D	N
	U-Factor 0.34			SHGC(N) 0.18				VT(N) 0.38		CR 39		



Total Quality. Assured.

130 Derry Court  
York, Pennsylvania 17406

Telephone: 717-764-7700  
Facsimile: 717-764-4129  
[www.intertek.com/building](http://www.intertek.com/building)

**TEST REPORT FOR EAGON WINDOWS & DOORS CO., LTD.**

Report No: L1411.02-116-45 R0 R0

Date: 09/03/21

**SECTION 7**

**DRAWINGS / BILL OF MATERIALS**

The drawings which follow have been reviewed by Intertek B&C and are representative of the simulation results reported herein. Any deviations are documented herein or on the drawings.

SYSTEM

ESS 70 SD MT

NOTE.

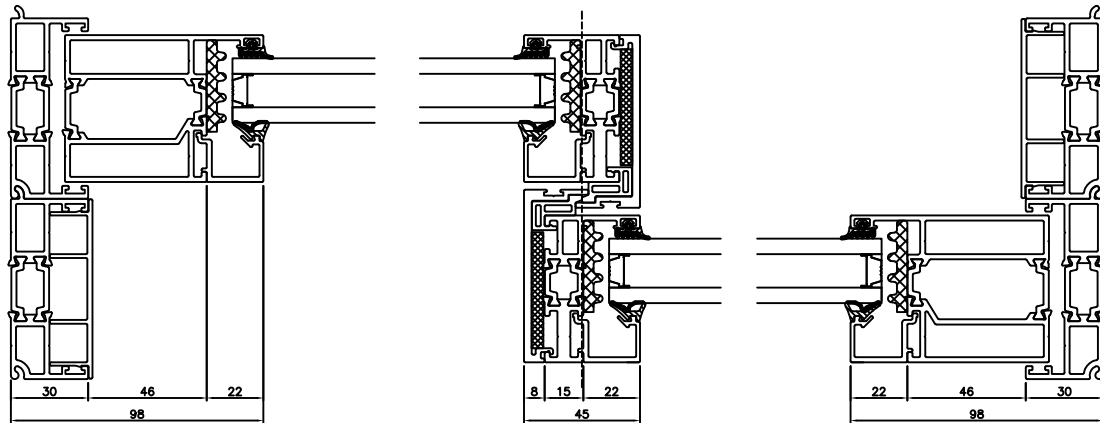
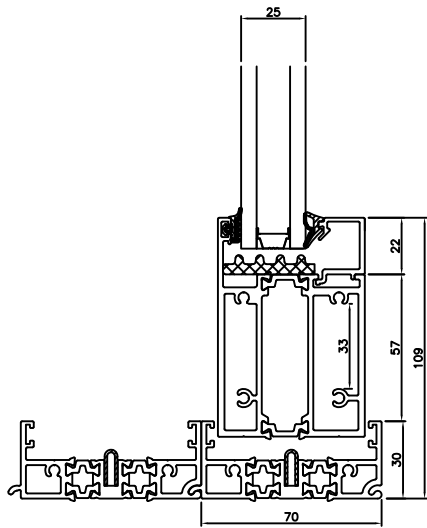
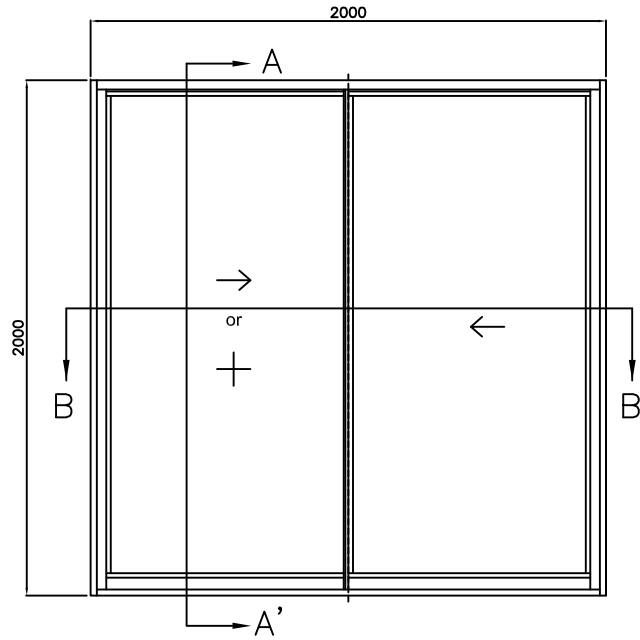
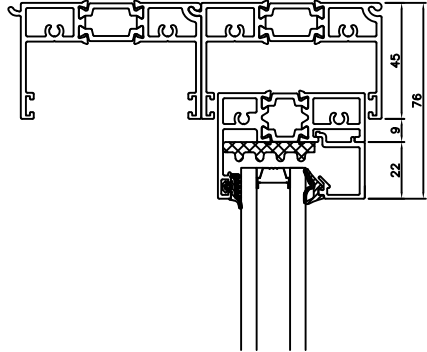

REV.	DESCRIPTION	DATE
△		
△		
△		
△		
△		
△		

CODE NO.

NFRC-01  
#7

PROJECT TITLE

DRAWING NAME

DRAWING BY

CHECKED BY

DATE

APPROVED BY

DRAWING NO

FILE NAME

SYSTEM

ESS 70 SD MT

NOTE.

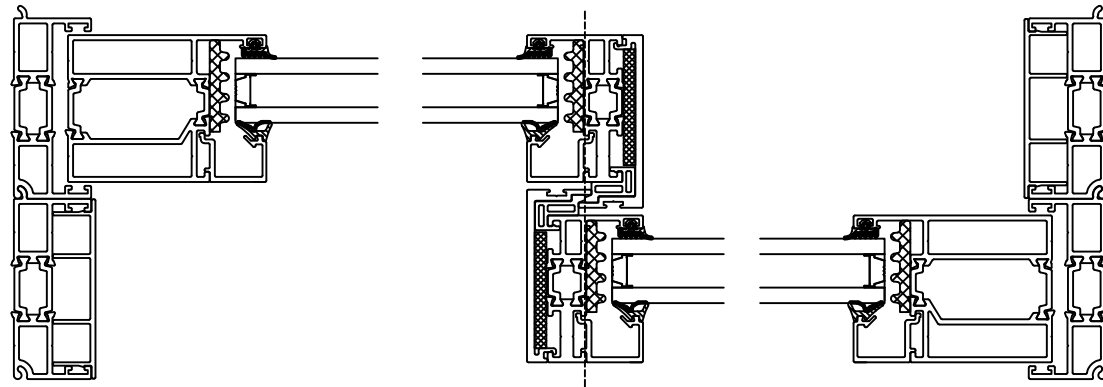
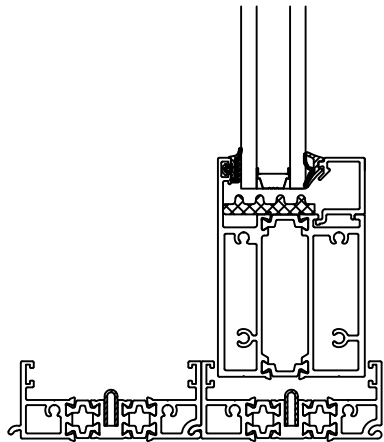
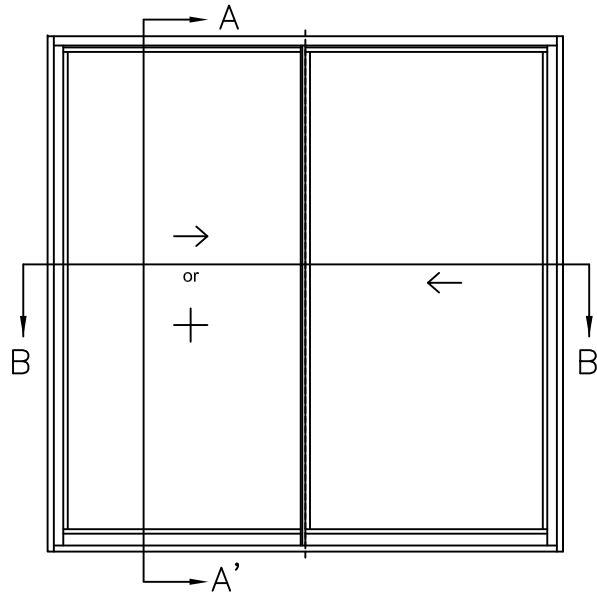
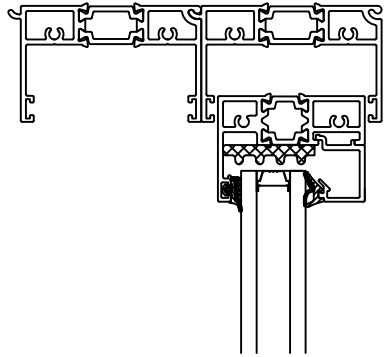

REV.	DESCRIPTION	DATE
△		
△		
△		
△		
△		
△		

CODE NO.

NFRC-01  
#7

PROJECT TITLE

DRAWING NAME

DRAWING BY

CHECKED BY

APPROVED BY

FILE NAME

DATE

DRAWING NO



( )

91 ( )

T 1522-1271 F (032) 760 009

## Appendix-A

Part Identification	Part Number	Material
Frame Head OUT	(1)	Painted Aluminum Alloy
Frame Head IN	(2)	Painted Aluminum Alloy
Frame Sill OUT	(3)	Painted Aluminum Alloy
Frame Sill IN	(4)	Painted Aluminum Alloy
Frame Sill Certer	(5)	Painted Aluminum Alloy
Vent Top OUT	(6)	Painted Aluminum Alloy
Vent Top IN	(7)	Painted Aluminum Alloy
Vent Bottom OUT	(8)	Painted Aluminum Alloy
Vent Bottom IN	(9)	Painted Aluminum Alloy
Frame Jamb OUT	(10)	Painted Aluminum Alloy
Frame Jamb IN	(11)	Painted Aluminum Alloy
Vent Stile OUT	(12)	Painted Aluminum Alloy
Vent Stile IN	(13)	Painted Aluminum Alloy
Vent End Stile OUT	(14)	Painted Aluminum Alloy
Vent End Stile IN	(15)	Painted Aluminum Alloy
Glazing Bead	(16)	Painted Aluminum Alloy
Frame Head/Jamb Insulation Bar	(17)	Polyamide 6.6 with 25%
Frame Sill Insulation Bar	(18)	Polyamide 6.6 with 25%
Vent Top/Bottom Insulation Bar	(19)	Polyamide 6.6 with 25%
Vent Stile Insulation Bar	(20)	Polyamide 6.6 with 25%
Outside Glazing Gasket	(21)	EPDM / EPDM Sponge
Inside Glazing Gasket	(22)	EPDM / EPDM Sponge
Spacer	(23)	Polyisobutylene(PIB)
		Stainless Steel
		Silicone
Vent Stile Insulation Foam	(24)	Polyurethane Foam
Glass Insulation Pad	(25)	Polyurethane Foam
Interlock Cover	(26)	Painted Aluminum Alloy
Jamb Cover	(27)	Painted Aluminum Alloy
Interlock PVC Cover	(28)	PVC

 <small>Total Quality. Assured.</small>	Report #:	L1411-116-45
	Date:	7/8/2020
	Verified by:	

Assembly Views : Vertical Section

Vent Head

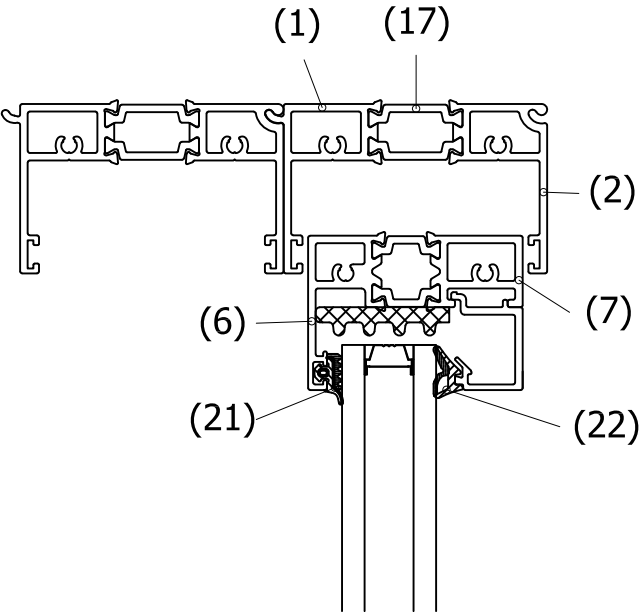

Vent Sill

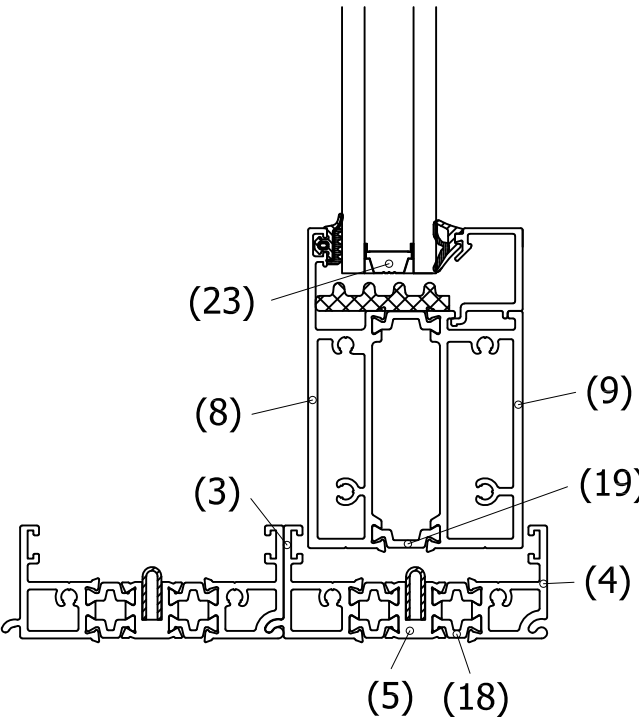

# Assembly Views : Horizontal Section

## Vent Jamb

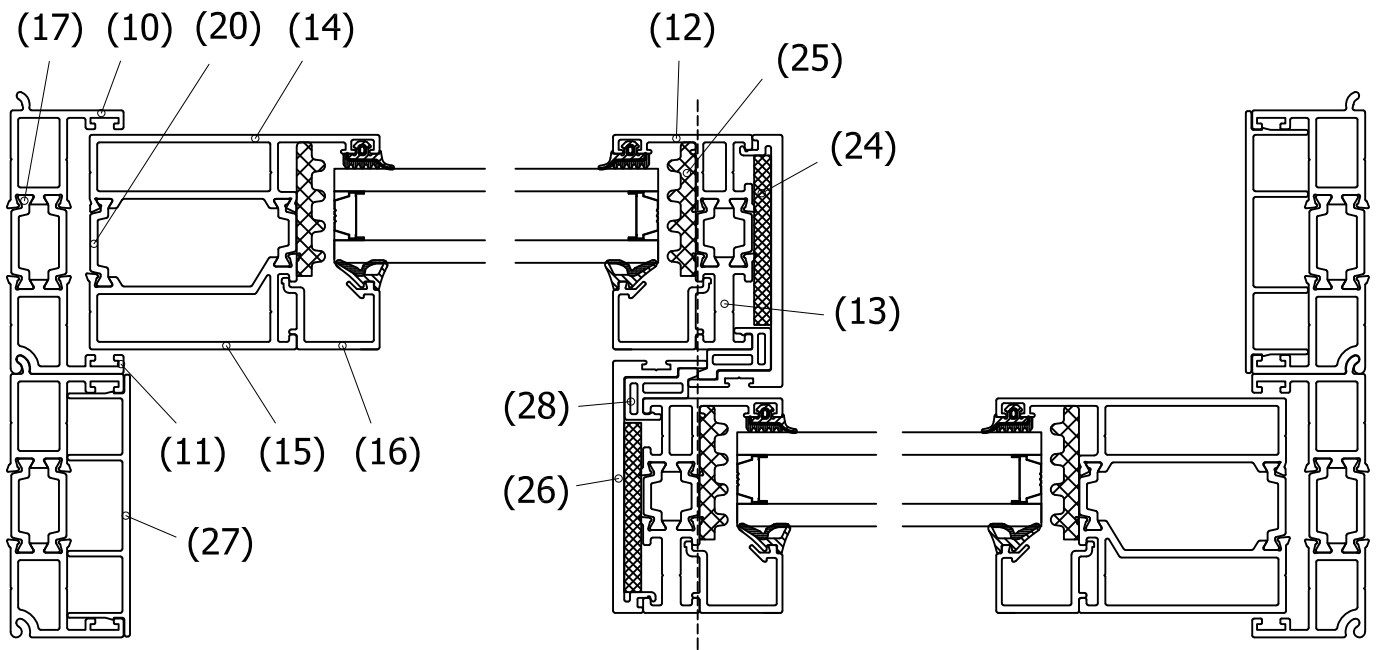



no.01

# Frame Head OUT

**intertek**  
Total Quality. Assured.

Report #: L1411-116-45  
Date: 7/8/2020  
Verified by: *[Signature]*

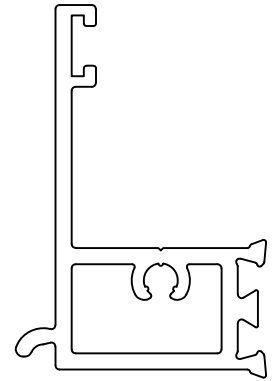

ACTUAL SIZE

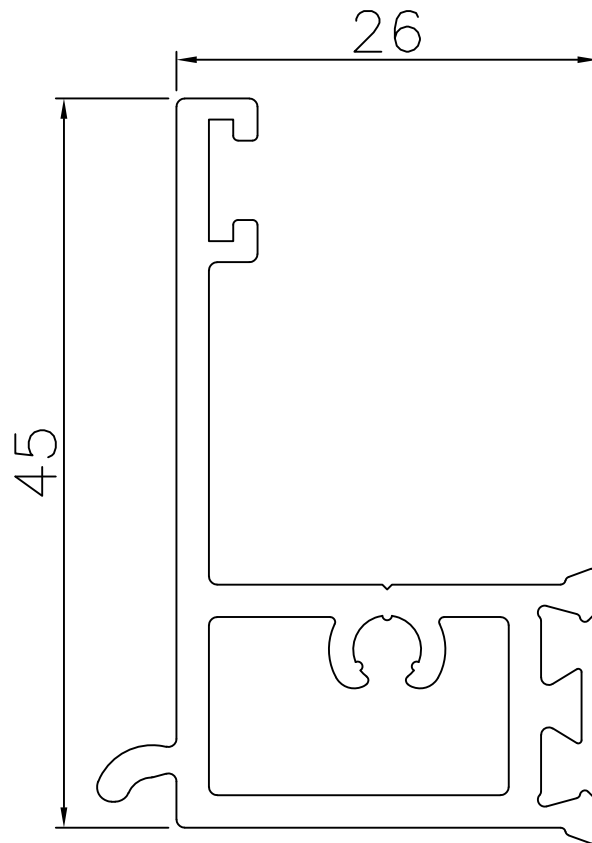

Material : Painted Aluminum Alloy

no.02

# Frame Head IN

**intertek**  
Total Quality. Assured.

Report #: L1411-116-45  
Date: 7/8/2020  
Verified by: *[Signature]*

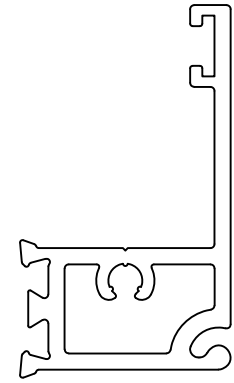

ACTUAL SIZE

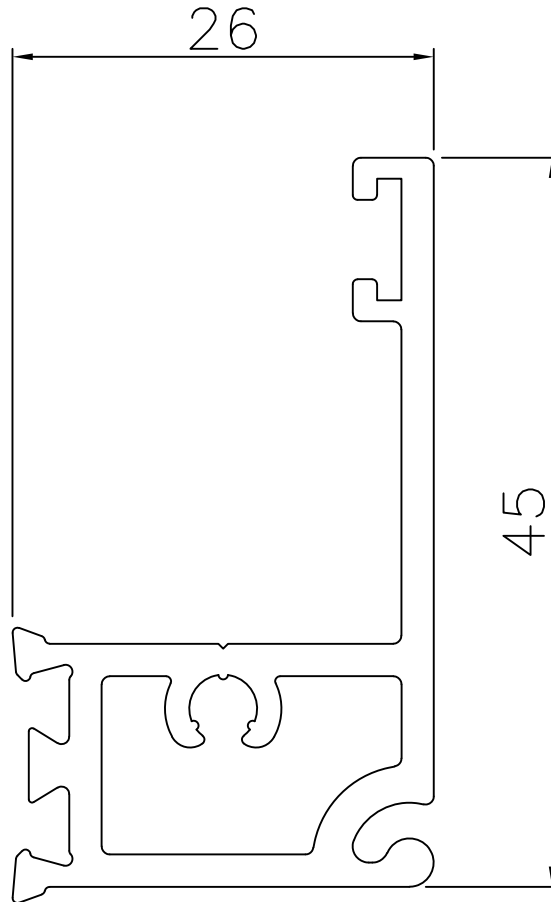

Material : Painted Aluminum Alloy

no.03

# Frame Sill OUT

**intertek**  
Total Quality. Assured.

Report #: L1411-116-45  
Date: 7/8/2020  
Verified by: *[Signature]*

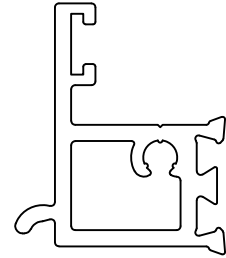

ACTUAL SIZE

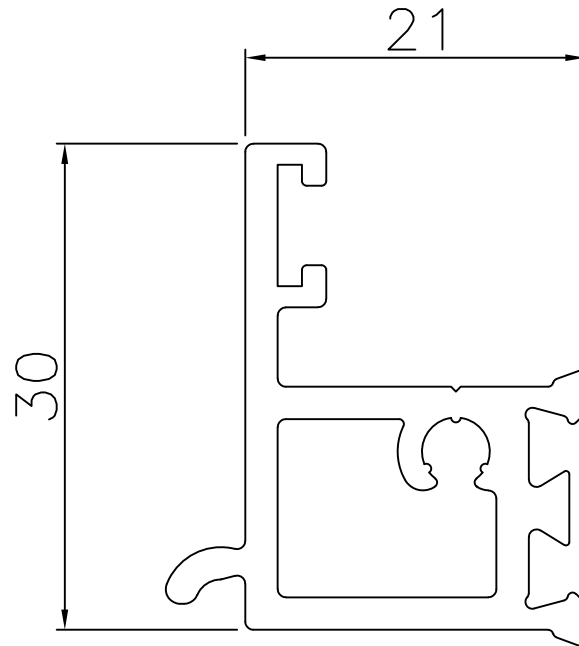

Material : Painted Aluminum Alloy

no.04

# Frame Sill IN

**intertek**  
Total Quality. Assured.

Report #: L1411-116-45  
Date: 7/8/2020  
Verified by: *[Signature]*

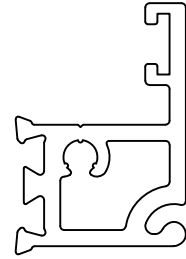

ACTUAL SIZE

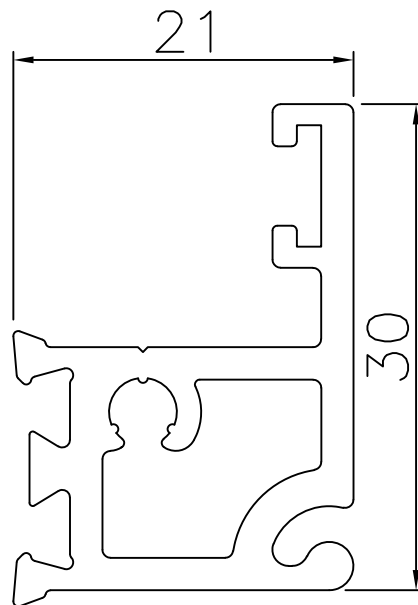

Material : Painted Aluminum Alloy

no.05

# Frame Sill Center

**intertek**  
Total Quality. Assured.

Report #: L1411-116-45  
Date: 7/8/2020  
Verified by: *[Signature]*

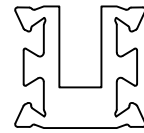

ACTUAL SIZE

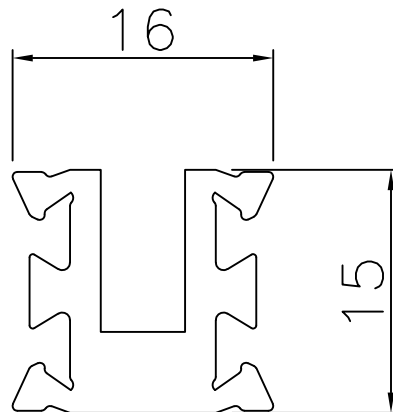

Material : Painted Aluminum Alloy

no.06

# Vent Top OUT

**intertek**  
Total Quality. Assured.

Report #:	L1411-116-45
Date:	7/8/2020
Verified by:	

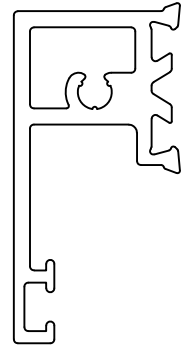

ACTUAL SIZE

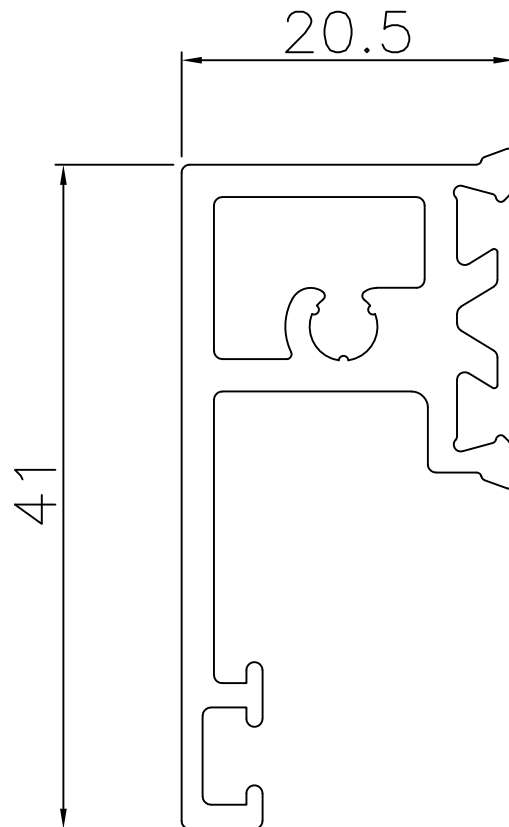

Material : Painted Aluminum Alloy

no.07

# Vent Top IN

**intertek**  
Total Quality. Assured.

Report #: L1411-116-45  
Date: 7/8/2020  
Verified by: *[Signature]*

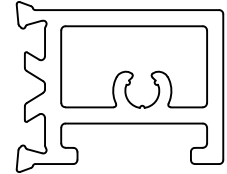

ACTUAL SIZE

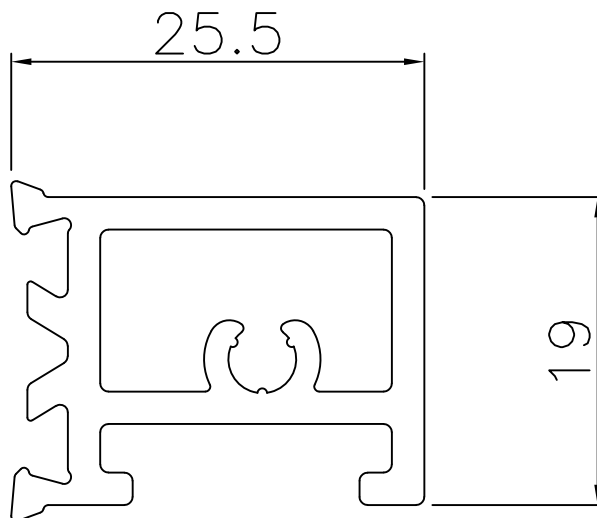

Material : Painted Aluminum Alloy

no.08

# Vent Bottom OUT

<b>intertek</b> Total Quality. Assured.	Report #:	L1411-116-45
	Date:	7/8/2020
	Verified by:	<i>[Signature]</i>

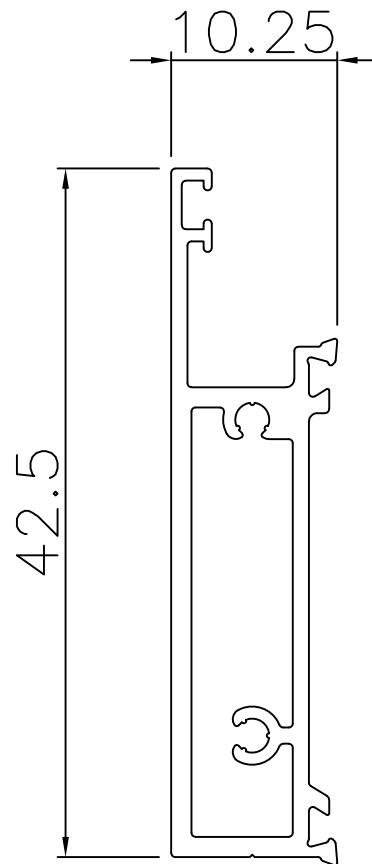

Material : Painted Aluminum Alloy



no.09

# Vent Bottom IN

**intertek**  
Total Quality. Assured.

Report #: L1411-116-45

Date: 7/8/2020

Verified by: *[Signature]*

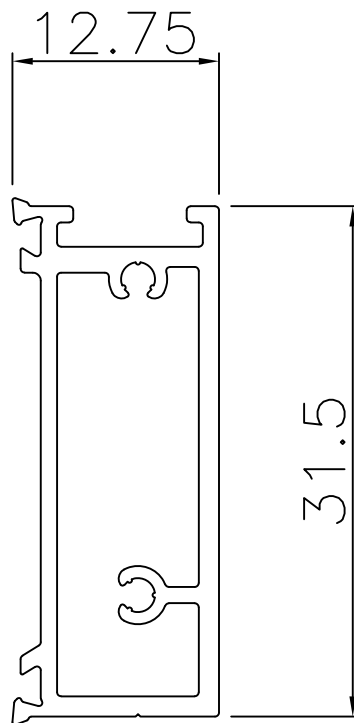

Material : Painted Aluminum Alloy

no.10

# Frame Jamb OUT

**intertek**  
Total Quality. Assured.

Report #:	L1411-116-45
Date:	7/8/2020
Verified by:	<i>[Signature]</i>

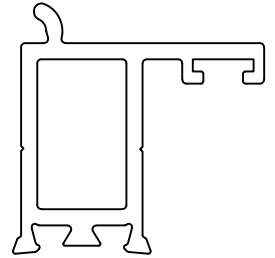

ACTUAL SIZE

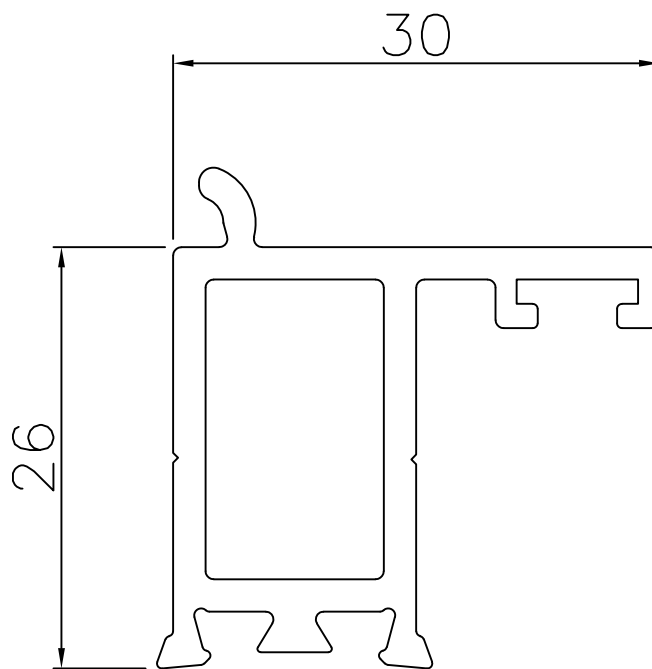

Material : Painted Aluminum Alloy

no.11

# Frame Jamb IN

**intertek**  
Total Quality. Assured.

Report #: L1411-116-45  
Date: 7/8/2020  
Verified by: *[Signature]*

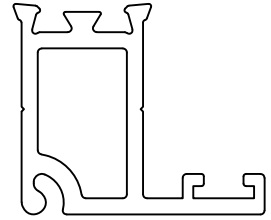

ACTUAL SIZE

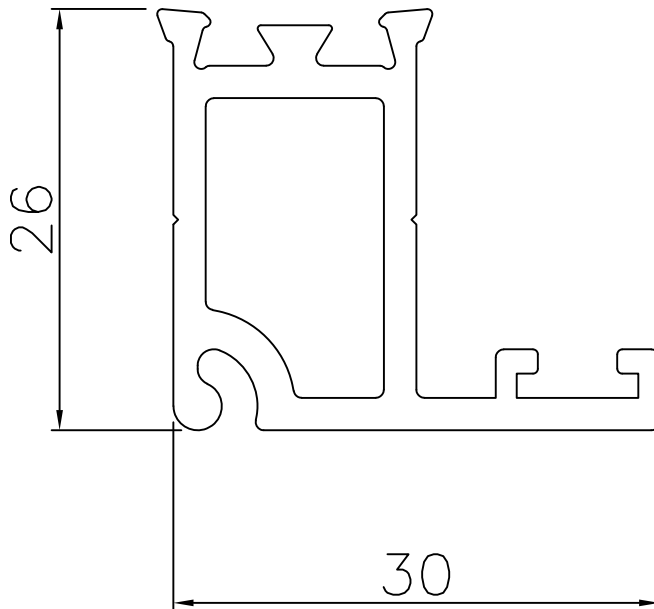

Material : Painted Aluminum Alloy

no.12

# Vent Stile OUT

**intertek**  
Total Quality. Assured.

Report #:	L1411-116-45
Date:	7/8/2020
Verified by:	

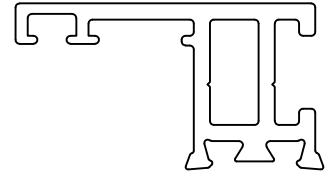

ACTUAL SIZE

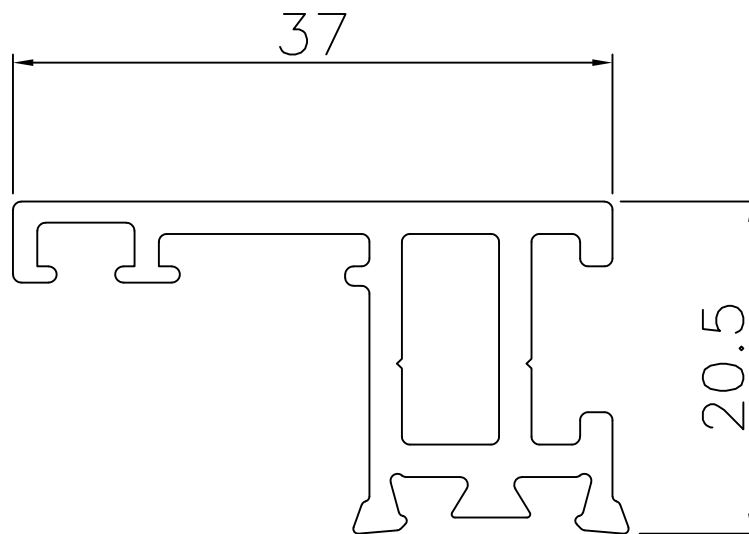

Material : Painted Aluminum Alloy

no.13

# Vent Stile IN

**intertek**  
Total Quality. Assured.

Report #: L1411-116-45  
Date: 7/8/2020  
Verified by: *[Signature]*

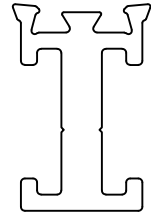

ACTUAL SIZE

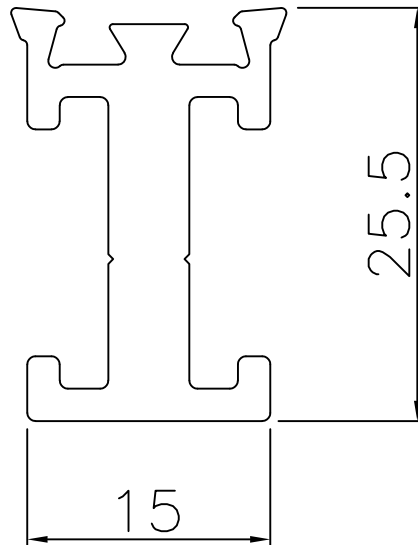

Material : Painted Aluminum Alloy

no.14

# Vent End Stile OUT

**intertek**  
Total Quality. Assured.

Report #: L1411-116-45  
Date: 7/8/2020  
Verified by: *[Signature]*

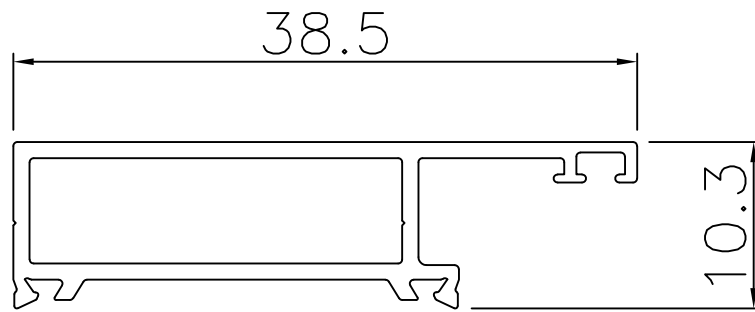

Material : Painted Aluminum Alloy

no.15

# Vent End Stile IN

**intertek**  
Total Quality. Assured.

Report #: L1411-116-45  
Date: 7/8/2020  
Verified by: 

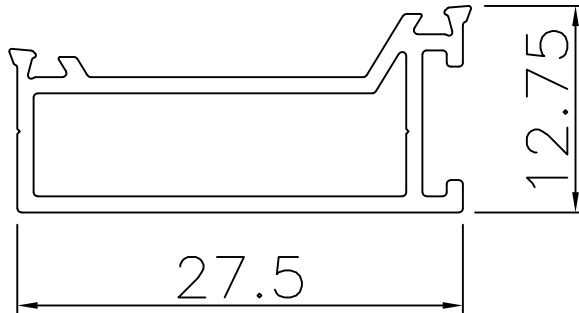

Material : Painted Aluminum Alloy

no.16

# Glazing Bead

**intertek**  
Total Quality. Assured.

Report #: L1411-116-45  
Date: 7/8/2020  
Verified by: *[Signature]*

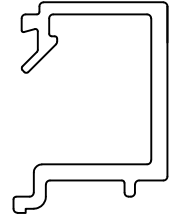

ACTUAL SIZE

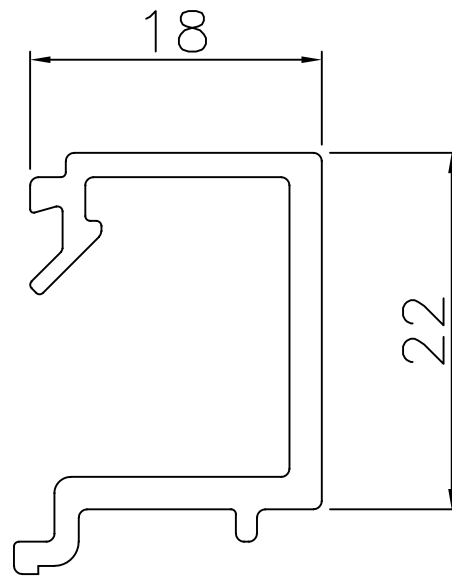

Material : Painted Aluminum Alloy



no.17

# Frame Head/Jamb Insulation Bar

**intertek**  
Total Quality. Assured.

Report #: L1411-116-45  
Date: 7/8/2020  
Verified by: *[Signature]*

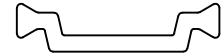

ACTUAL SIZE

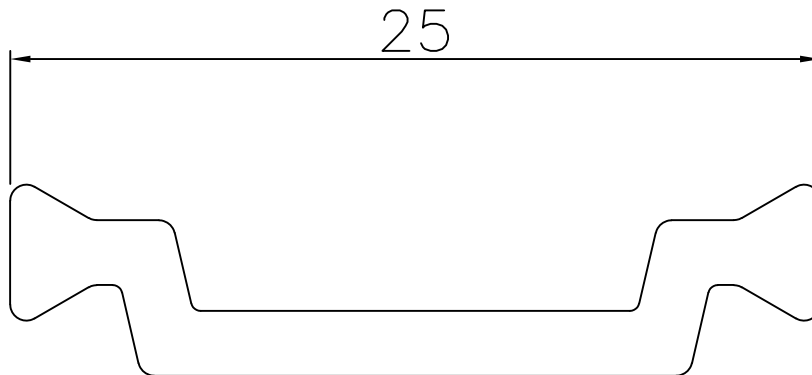

Material : Polyamide 6.6 with 25% glass fiber

no.18

# Frame Sill Insulation Bar

**intertek**  
Total Quality. Assured.

Report #: L1411-116-45  
Date: 7/8/2020  
Verified by: 

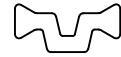

ACTUAL SIZE

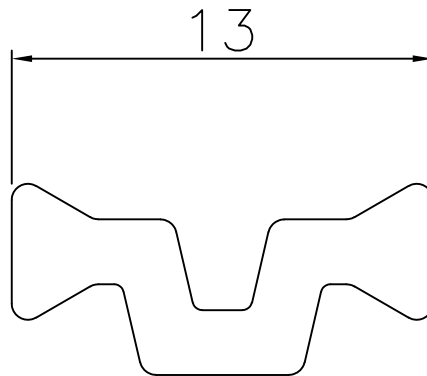

Material : Polyamide 6.6 with 25% glass fiber

no.19

# Vemt Top/Bottom Insulation Bar

**intertek**  
Total Quality. Assured.

Report #: L1411-116-45  
Date: 7/8/2020  
Verified by: *[Signature]*



ACTUAL SIZE

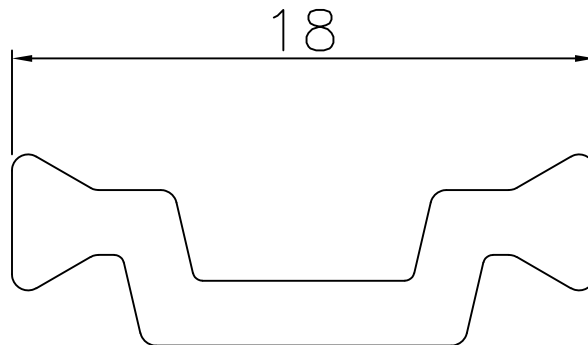

Material : Polyamide 6.6 with 25% glass fiber

no.20

# Vent Stile Insulation Bar

**intertek**  
Total Quality. Assured.

Report #: L1411-116-45  
Date: 7/8/2020  
Verified by: *[Signature]*

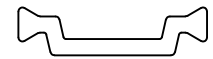

ACTUAL SIZE

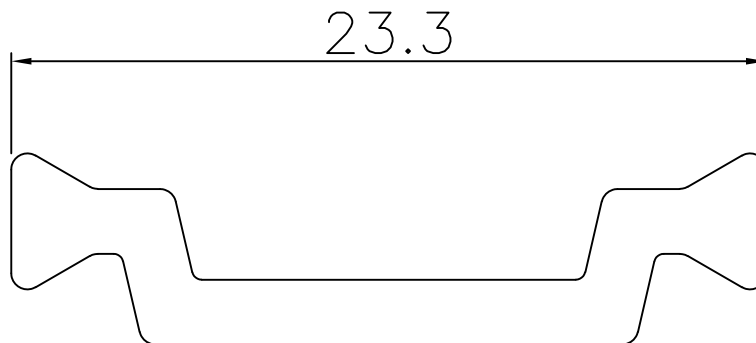

Material : Polyamide 6.6 with 25% glass fiber

no.21

# Outside Glazing Gasket

**intertek**  
Total Quality. Assured.

Report #: L1411-116-45  
Date: 7/8/2020  
Verified by: 



ACTUAL SIZE

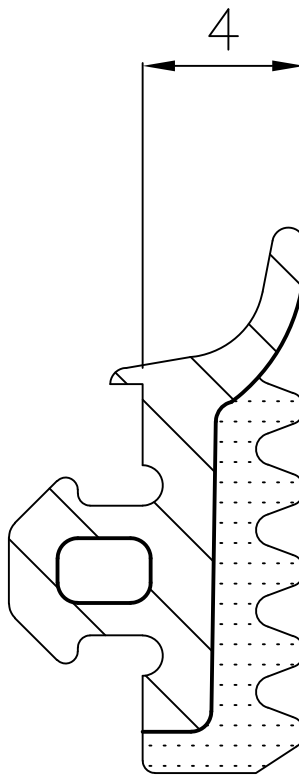

Material : EPDM / EPDM SPONGE

no.22

# Inside Glazing Gasket

**intertek**  
Total Quality. Assured.

Report #:	L1411-116-45
Date:	7/8/2020
Verified by:	



ACTUAL SIZE

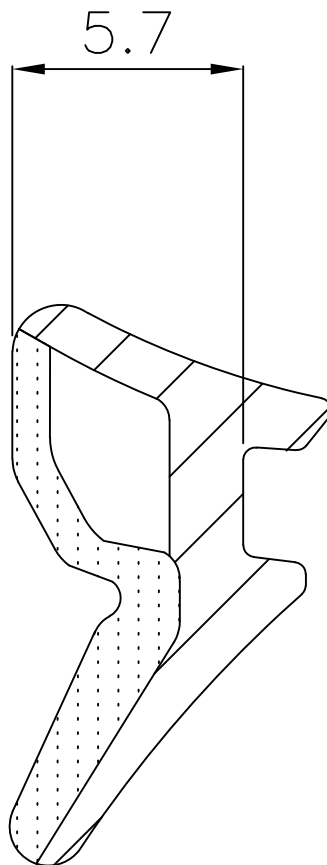

Material : EPDM / EPDM SPONGE

no.24

# Vent Stile Insulation Foam

**intertek**  
Total Quality. Assured.

Report #: L1411-116-45  
Date: 7/8/2020  
Verified by: *[Signature]*

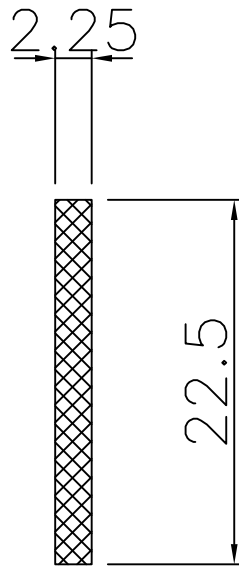

Material : Polyurethane Foam

no.25

# Glass Insulation Pad

**intertek**  
Total Quality. Assured.

Report #: L1411-116-45  
Date: 7/8/2020  
Verified by: *[Signature]*

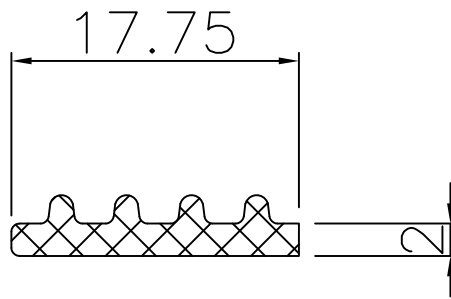

Material : Polyurethane Foam



no.26

# Interlock Cover

**intertek**  
Total Quality. Assured.

Report #:	L1411-116-45
Date:	7/8/2020
Verified by:	<i>[Signature]</i>

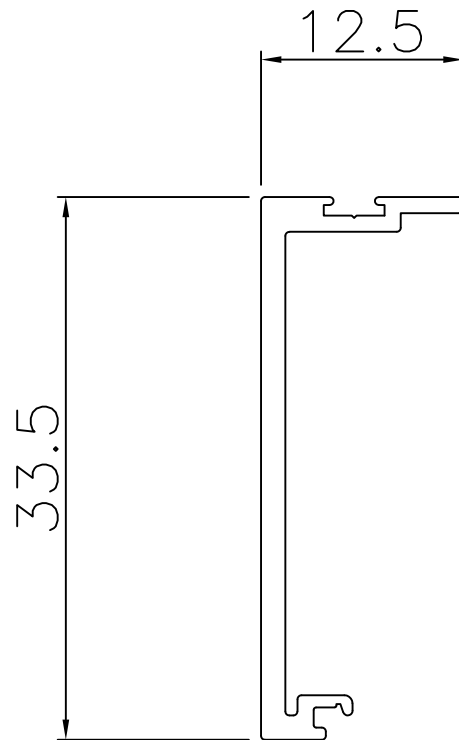

Material : Painted Aluminum Alloy

no.27

# Jamb Cover



Report #: L1411-116-45  
Date: 7/8/2020  
Verified by: *[Signature]*

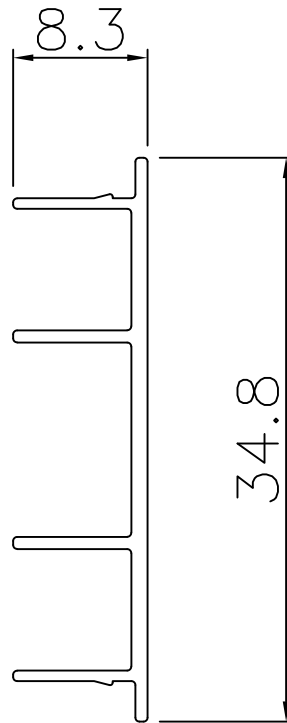

Material : Painted Aluminum Alloy

no.28

# Interlock PVC Cover

**intertek**  
Total Quality. Assured.

Report #: L1411-116-45

Date: 7/8/2020

Verified by: 

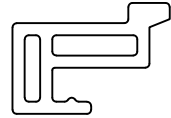

ACTUAL SIZE

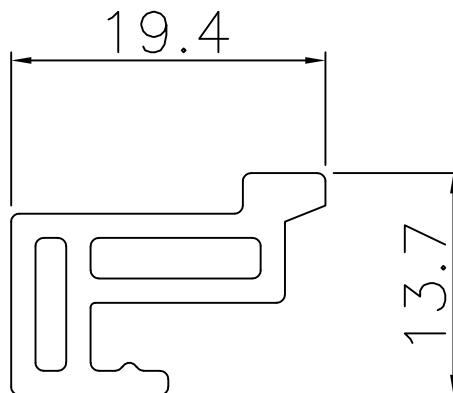

Material : PVC

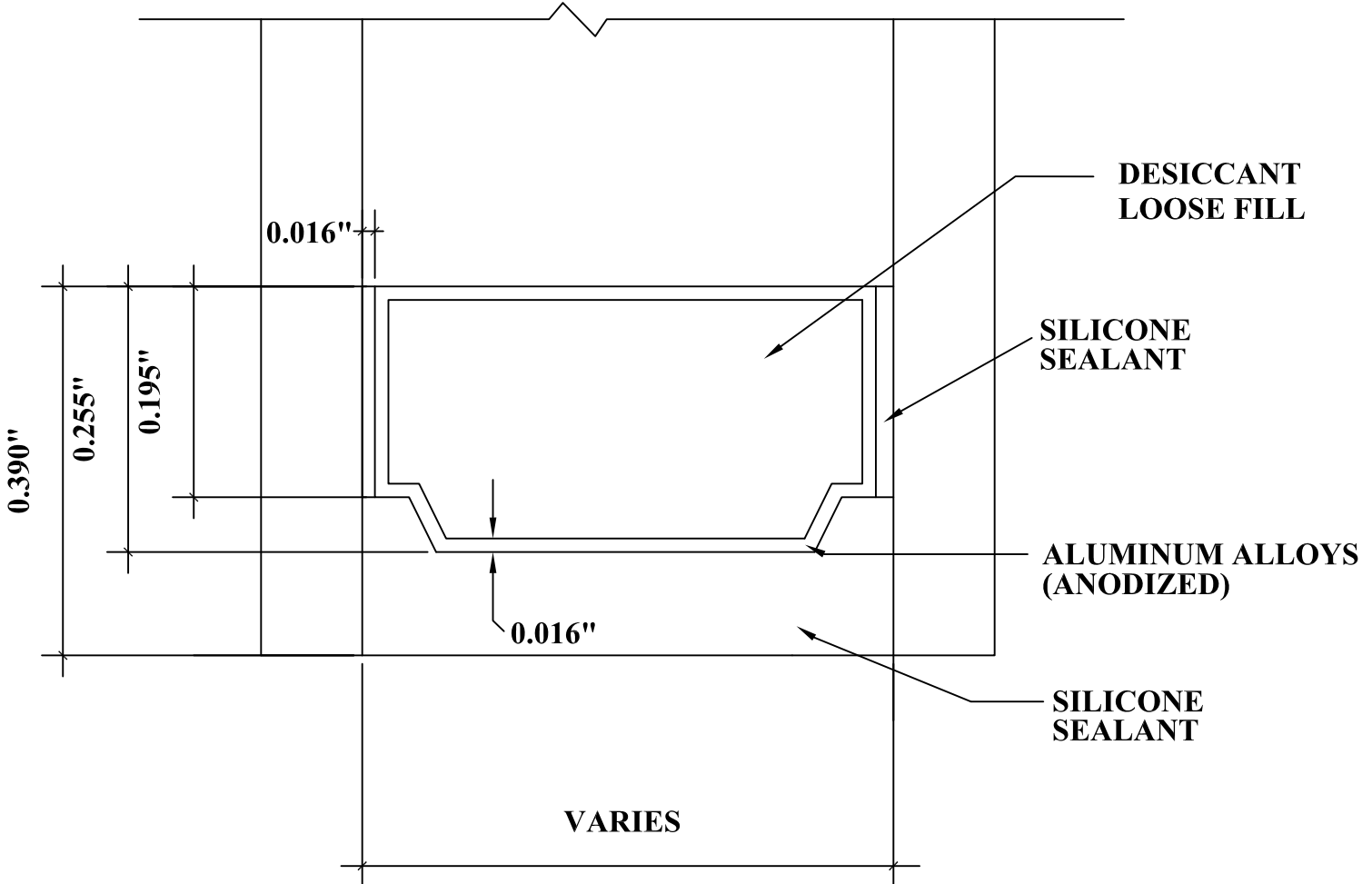

DETAIL FOR THERMAL MODELING OF ALLMETAL LPX ANODIZED ALUMINUM SPACER

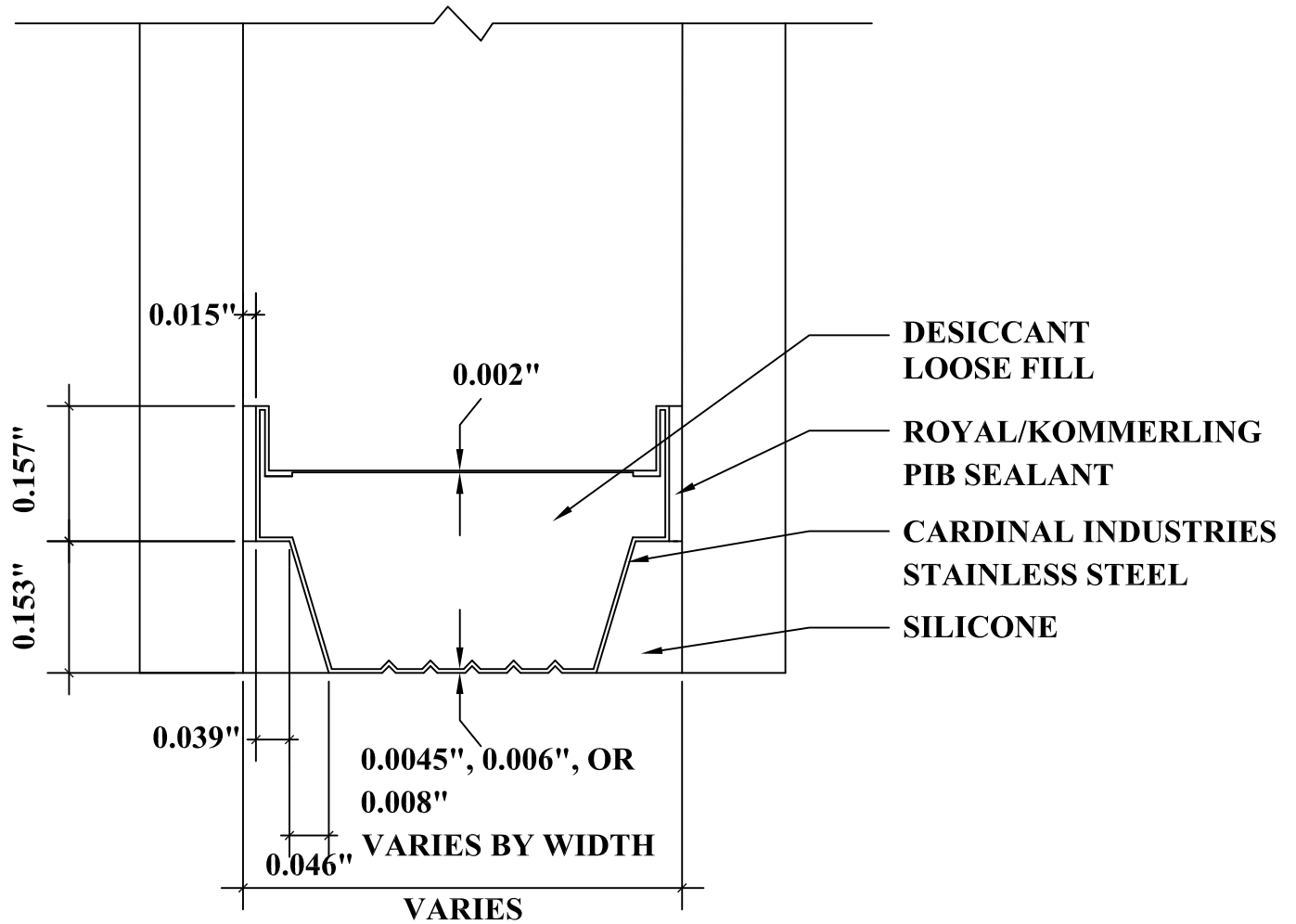

DETAIL FOR THERMAL MODELING OF  
CARDINAL ENDUR SPACER (SS-D)

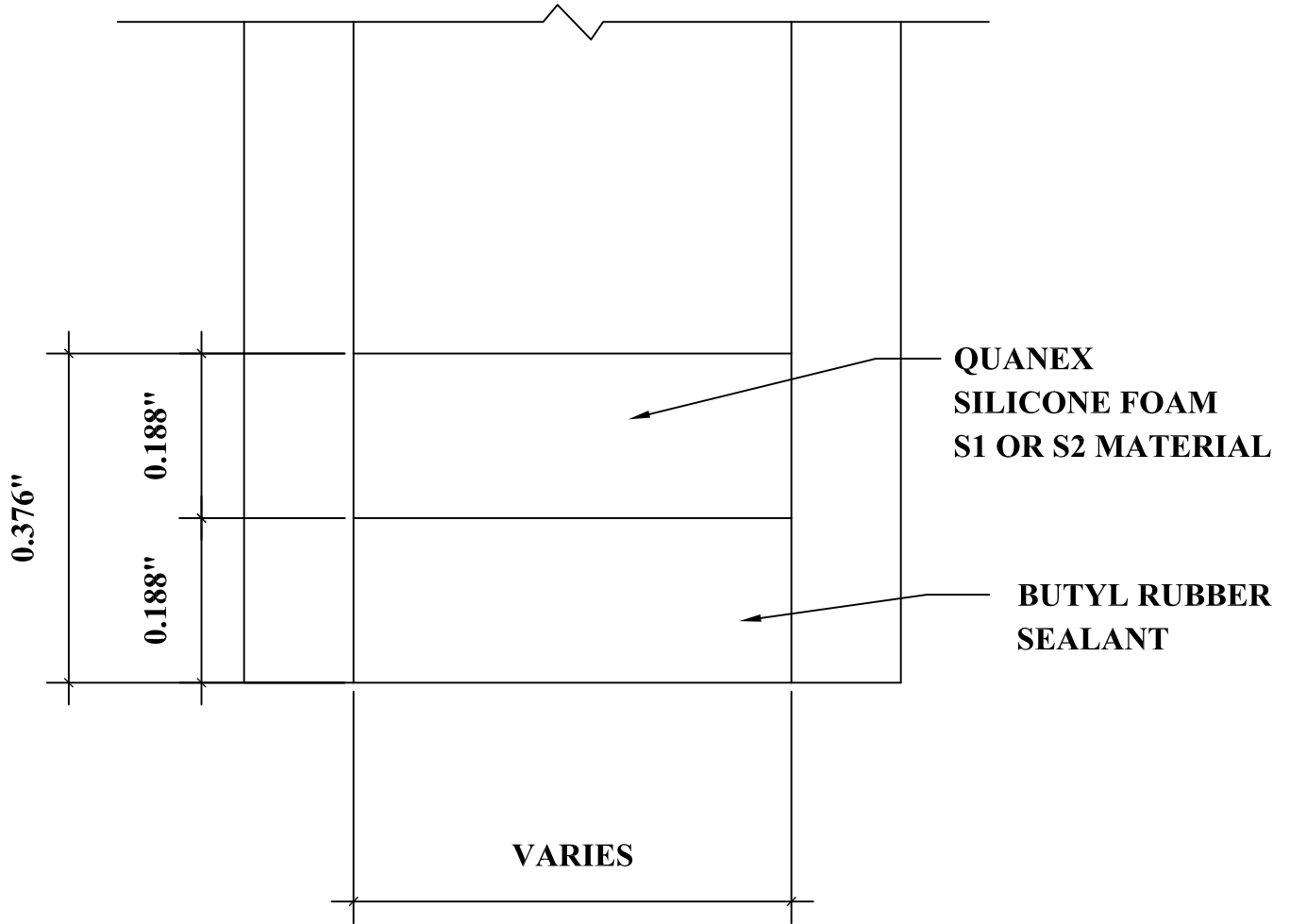

DETAIL FOR THERMAL MODELING OF  
QUANEX SUPER SPACER PREMIUM (ZF-S)

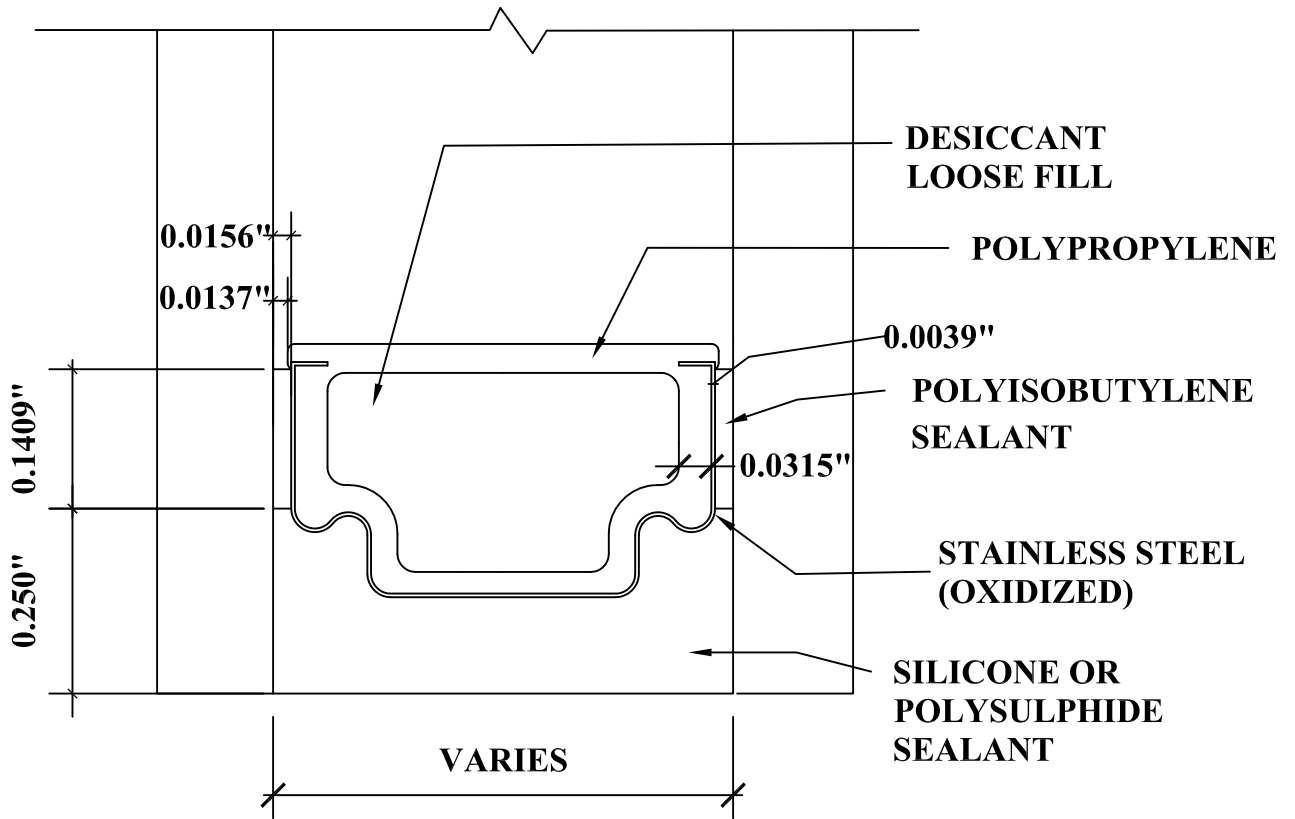

DETAIL FOR THERMAL MODELING OF  
TECHNOFORM TGI SPACER - TIS (TS-D)

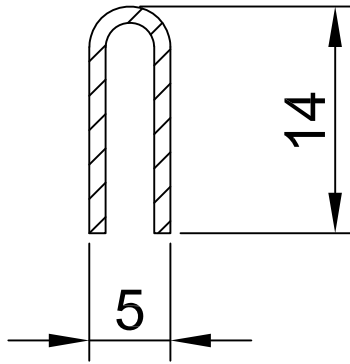

**1mm Typical Wall Thickness**  
**Material : Stainless Steel**



SYSTEM  
ESS 70 SD MT

NOTE.

REV.	DESCRIPTION	DATE
△		
△		
△		
△		
△		
△		

CODE NO.

NFRC-01  
#1

PROJECT TITLE

DRAWING NAME

DRAWING BY

CHECKED BY DATE

APPROVED BY DRAWING NO

FILE NAME

( )

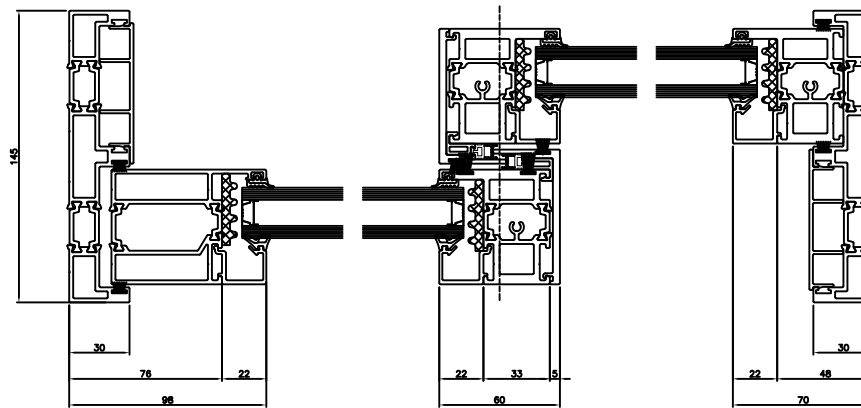
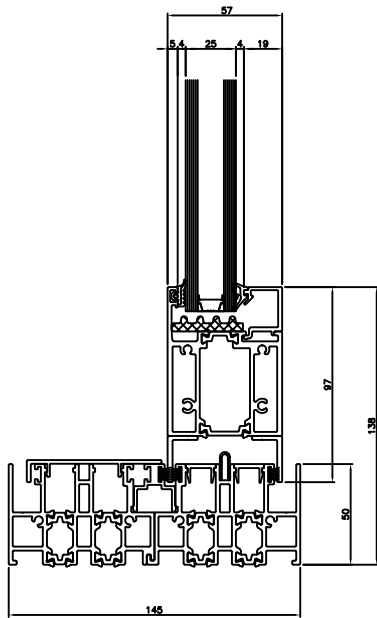
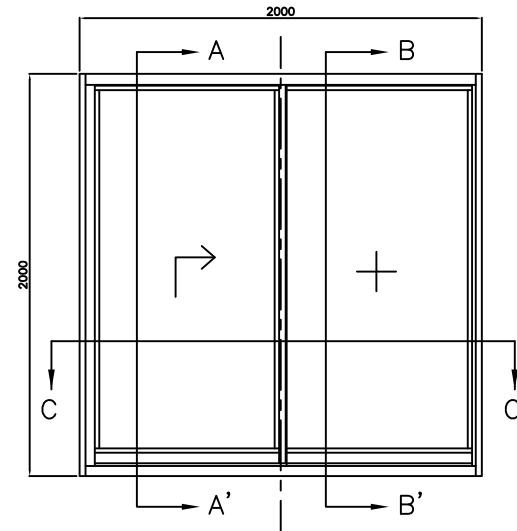
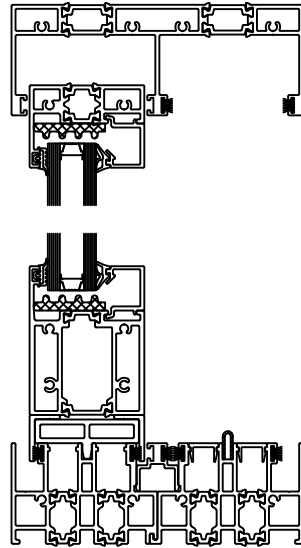
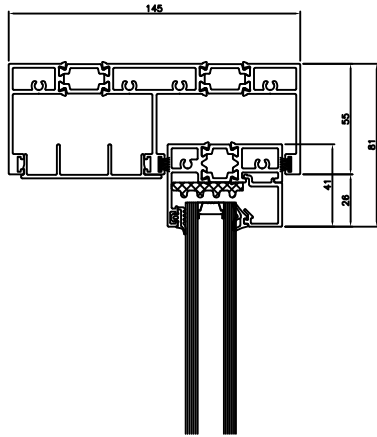

Bill of Materials		Appendix-A
Part Identification	Part Number	Material
Frame Sill IN/OUT	(1)	Painted Aluminum Alloy
Frame Sill Male	(2)	Painted Aluminum Alloy
Frame Sill Female	(3)	Painted Aluminum Alloy
Frame Sill Middle	(4)	Painted Aluminum Alloy
Frame Head IN/OUT	(5)	Painted Aluminum Alloy
Frame Head Middle	(6)	Painted Aluminum Alloy
Frame Jamb IN/OUT	(7)	Painted Aluminum Alloy
Frame Jamb Middle	(8)	Painted Aluminum Alloy
Frame Sill Attach	(9)	Painted Aluminum Alloy
Frame Cover1	(10)	Painted Aluminum Alloy
Frame Cover2	(11)	Painted Aluminum Alloy
Vent Bottom IN	(12)	Painted Aluminum Alloy
Vent Bottom OUT	(13)	Painted Aluminum Alloy
Vent Top IN	(14)	Painted Aluminum Alloy
Vent Top OUT	(15)	Painted Aluminum Alloy
Vent Stile IN	(16)	Painted Aluminum Alloy
Vent Stile OUT	(17)	Painted Aluminum Alloy
Vent Interlock IN	(18)	Painted Aluminum Alloy
Vent Interlock OUT1	(19)	Painted Aluminum Alloy
Vent Interlock OUT2	(20)	Painted Aluminum Alloy
Vent Interlock Cover	(21)	Painted Aluminum Alloy
VENT Bottom Attach	(22)	Painted Aluminum Alloy
Vent Bead	(23)	Painted Aluminum Alloy
Frame Insulation Bar 13mm	(24)	Polyamide 6.6 with 25%
Vent Insulation Bar 18mm	(25)	Polyamide 6.6 with 25%
Vent Insulation Bar 23.3mm	(26)	Polyamide 6.6 with 25%
Frame Insulation Bar 25mm	(27)	Polyamide 6.6 with 25%
Frame Sill Attach	(28)	PVC
Interlock Cover Attach	(29)	PVC
Interlock Cover Gasket	(30)	EPDM / EPDM Sponge
Inside Glazing Gasket	(31)	EPDM / EPDM Sponge
Outside Glazing Gasket	(32)	EPDM / EPDM Sponge
Glass Insulation Pad	(33)	Polyurethane Foam
Frame Sill Rail	(34)	Stainless Steel
Frame Mohair 7x5	(35)	Mohair
Frame Mohair 7x7	(36)	Mohair
Frame Mohair 7x10	(37)	Mohair
Spacer	(38)	Polyisobutylene(PIB)
		Stainless Steel
		Silicone

**Intertek**  
 Total Quality Assured  
 Report #: 11411-116-45  
 Date: 7/8/2020  
 Verified by: 

### Assembly Views : Vertical Section

Vent Head

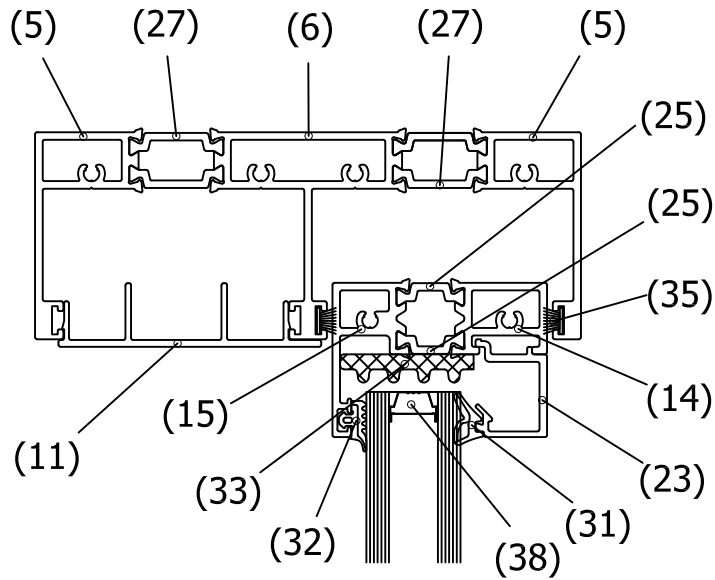

Vent Sill

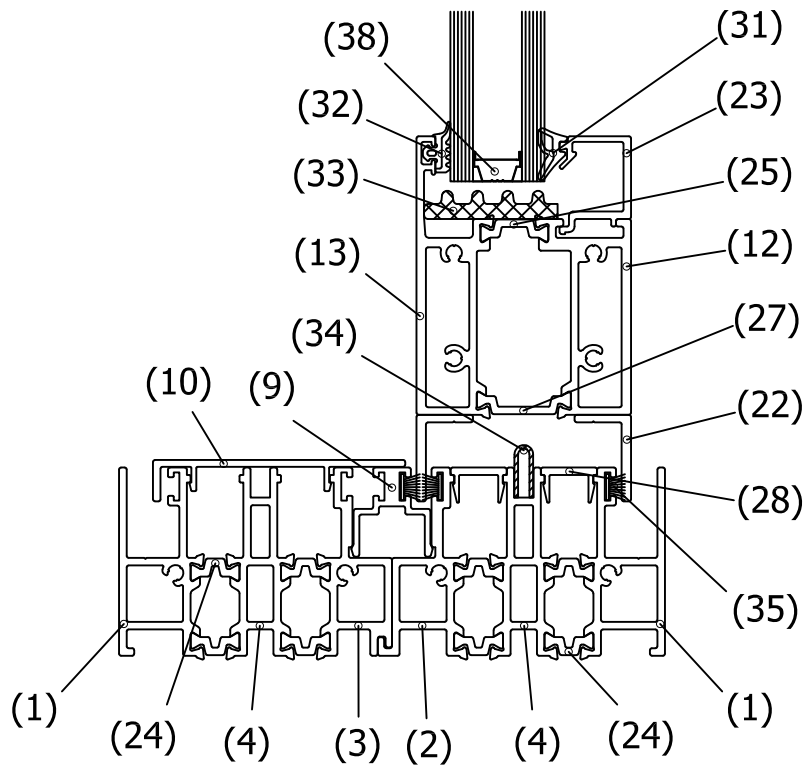

# Assembly Views : Horizontal Section

## Vent Jamb

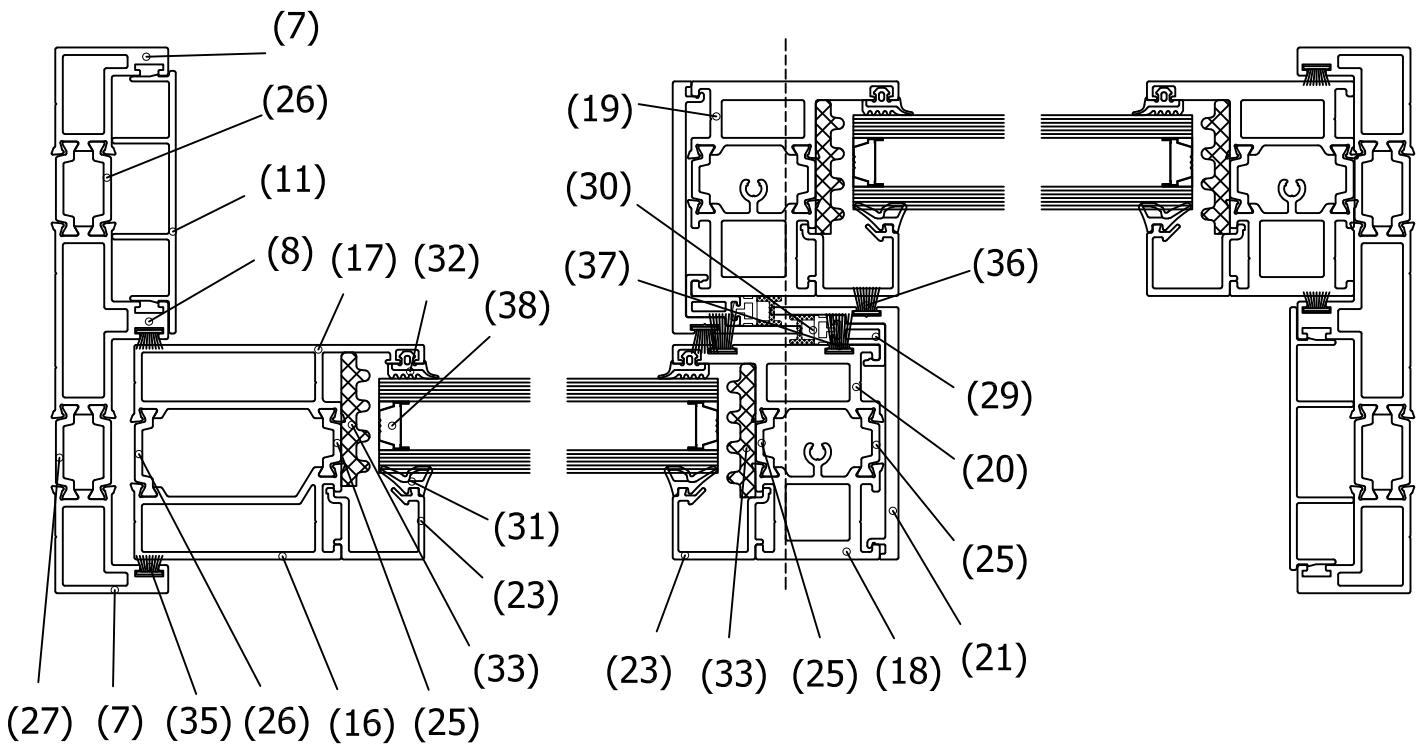

no.01

Frame Sill IN/OUT

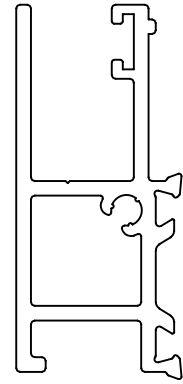
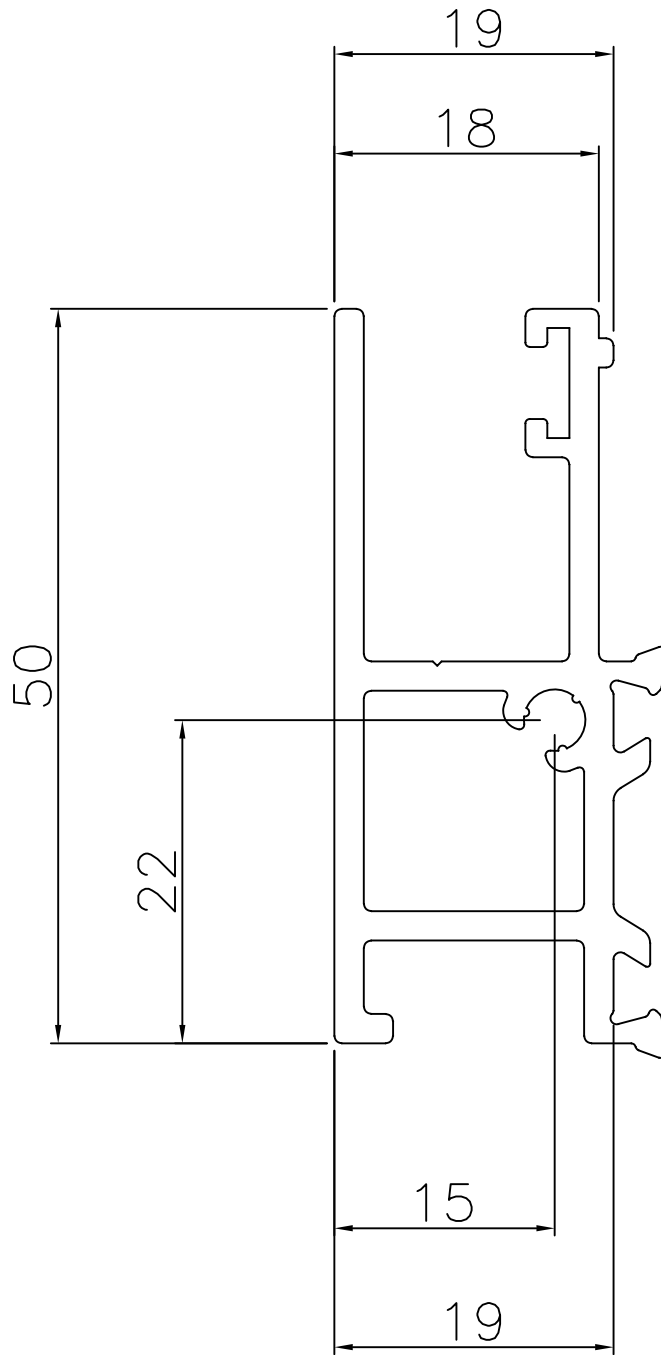

ACTUAL SIZE

Material : Painted Aluminum Alloy

**intertek**  
Total Quality Assured.

Report #: L1411-116-45  
Date: 7/8/2020  
Verified by: 

no.02

# Frame Sill Male

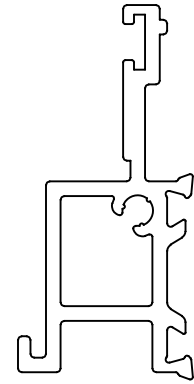
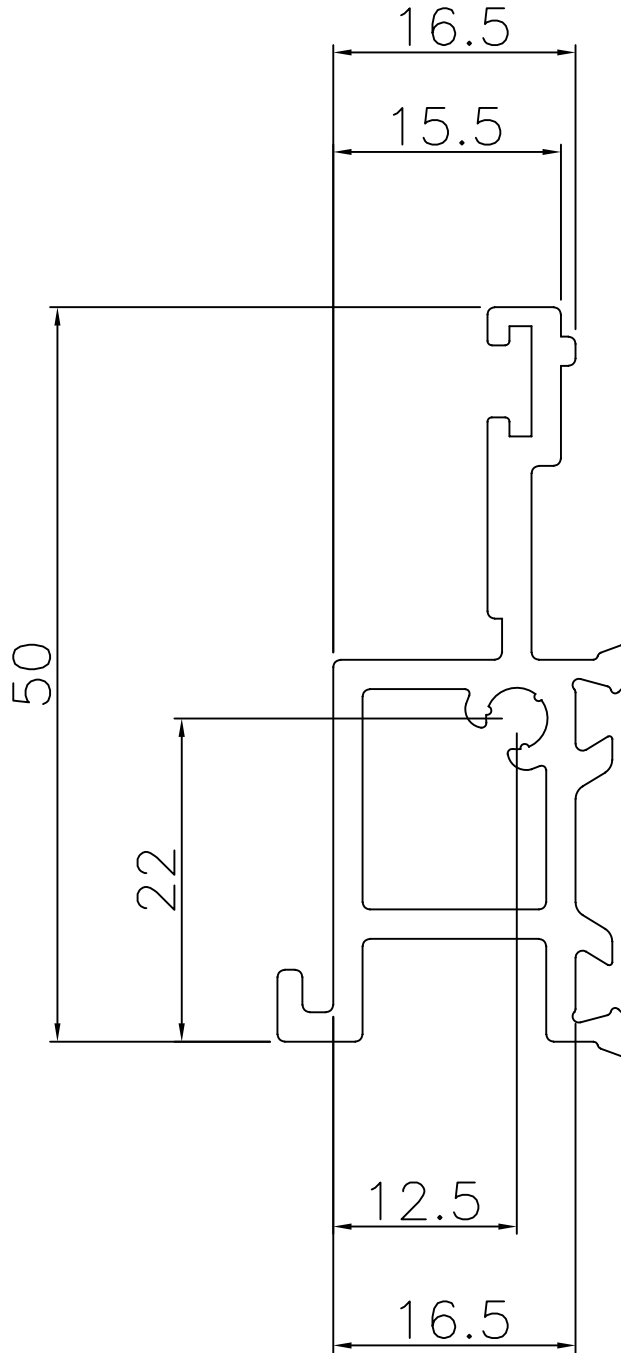

ACTUAL SIZE

Material : Painted Aluminum Alloy

**Intertek**  
Total Quality Assured.

Report #:	L1411-116-45
Date:	7/8/2020
Verified by:	

no.03

# Frame Sill Female

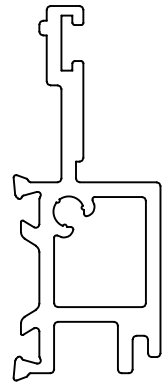
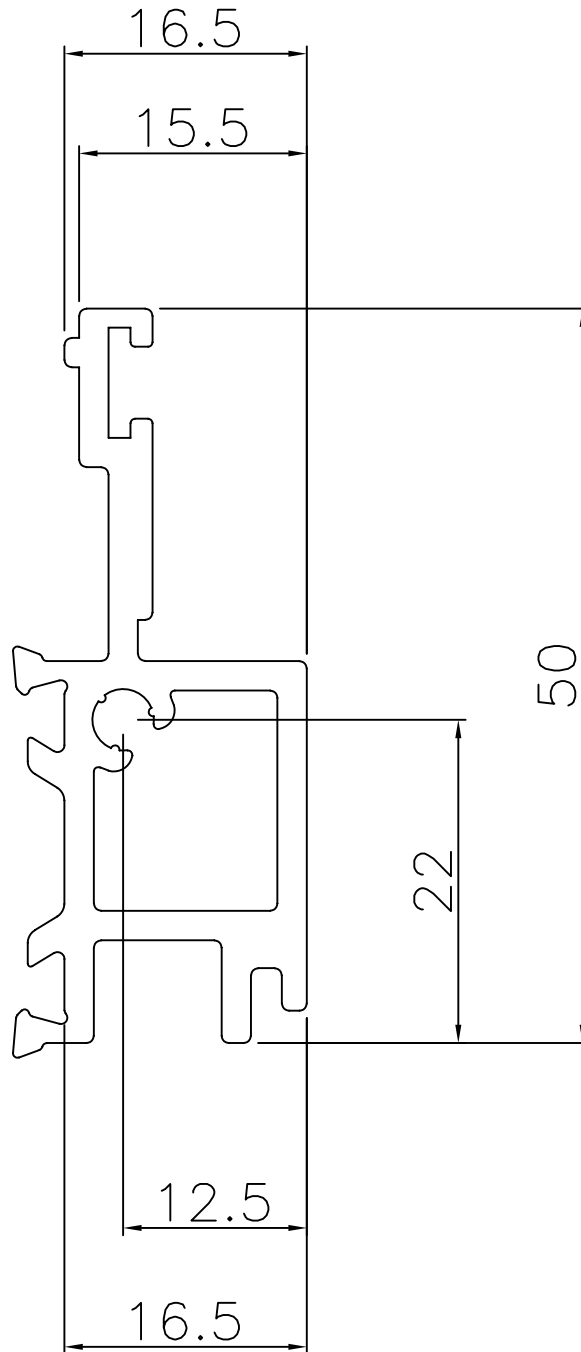

ACTUAL SIZE

Material : Painted Aluminum Alloy

**intertek**  
Total Quality Assured.

Report #:	L1411-116-45
Date:	7/8/2020
Verified by:	

no.04

# Frame Sill Middle

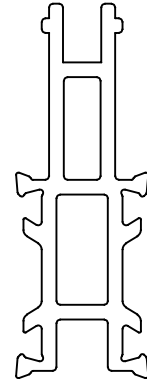
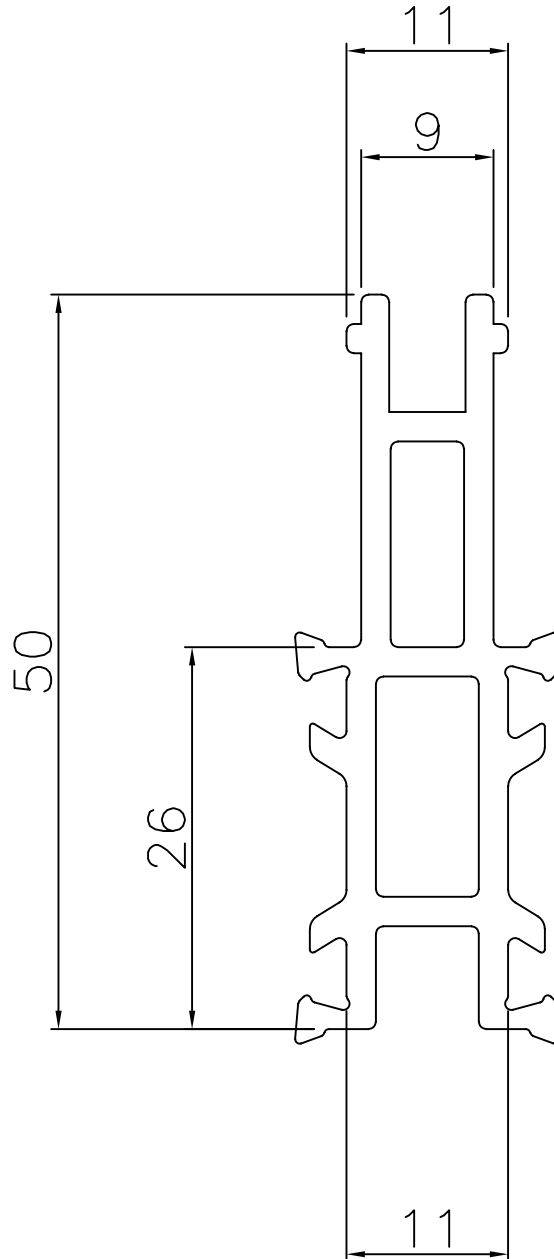

ACTUAL SIZE

Material : Painted Aluminum Alloy

**intertek**  
Total Quality Assured.

Report #:	L1411-116-45
Date:	7/8/2020
Verified by:	



no.05

# Frame Head IN/OUT

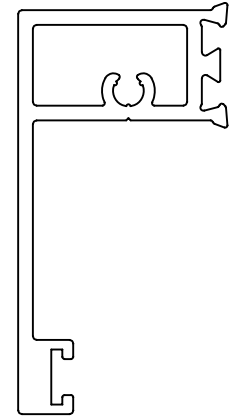
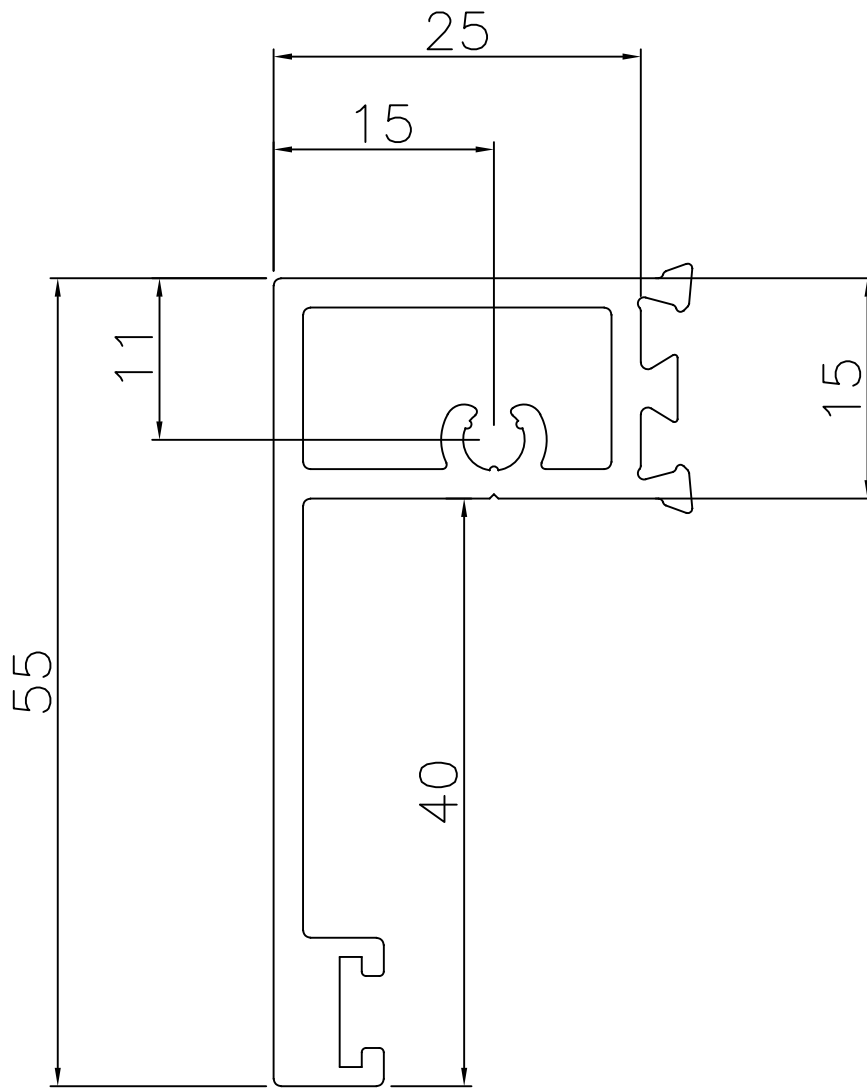

ACTUAL SIZE

Material : Painted Aluminum Alloy

**intertek**  
Total Quality Assured.

Report #:	L1411-116-45
Date:	7/8/2020
Verified by:	

no.06

# Frame Head Middle

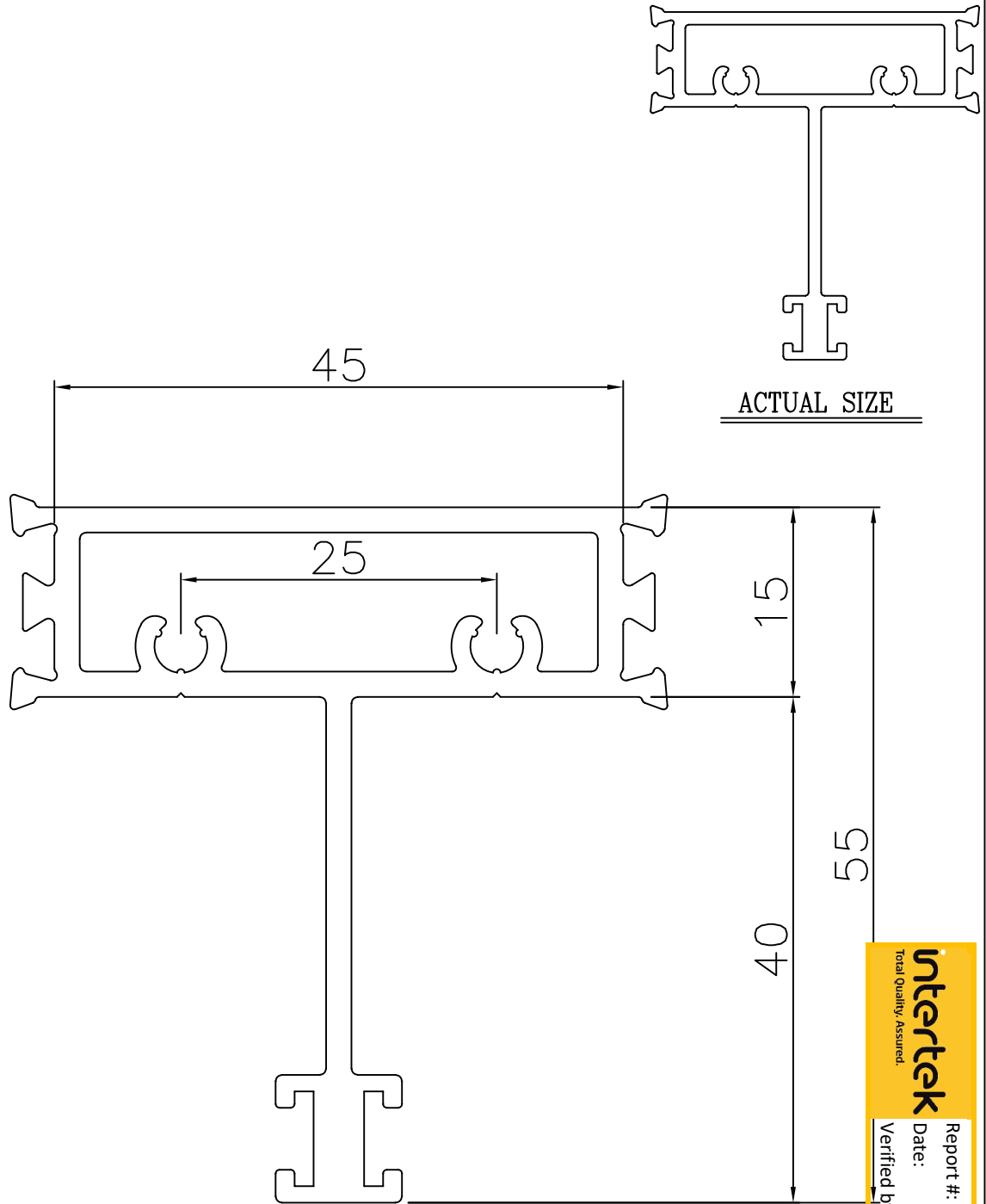

Material : Painted Aluminum Alloy

**intertek**  
Total Quality Assured.

Report #:	L1411-116-45
Date:	7/8/2020
Verified by:	

no.07

Frame Jamb IN/OUT

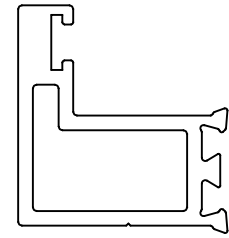

ACTUAL SIZE

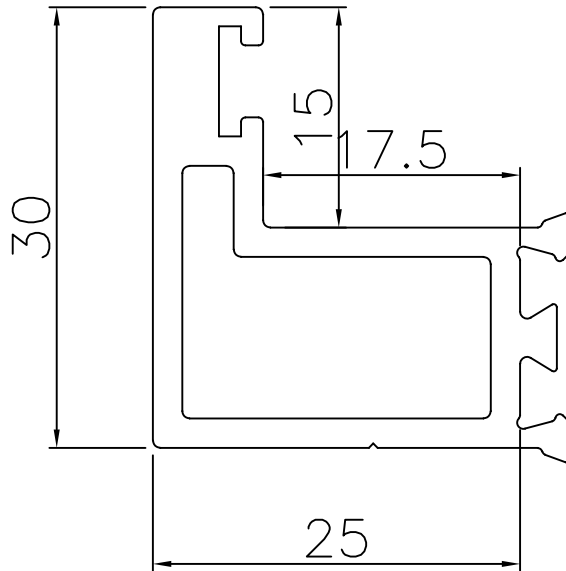

Material : Painted Aluminum Alloy

**intertek**  
Total Quality Assured.

Report #:	L1411-116-45
Date:	7/8/2020
Verified by:	

no.08

# Frame Jamb Middle

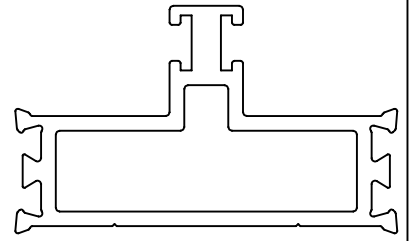

ACTUAL SIZE

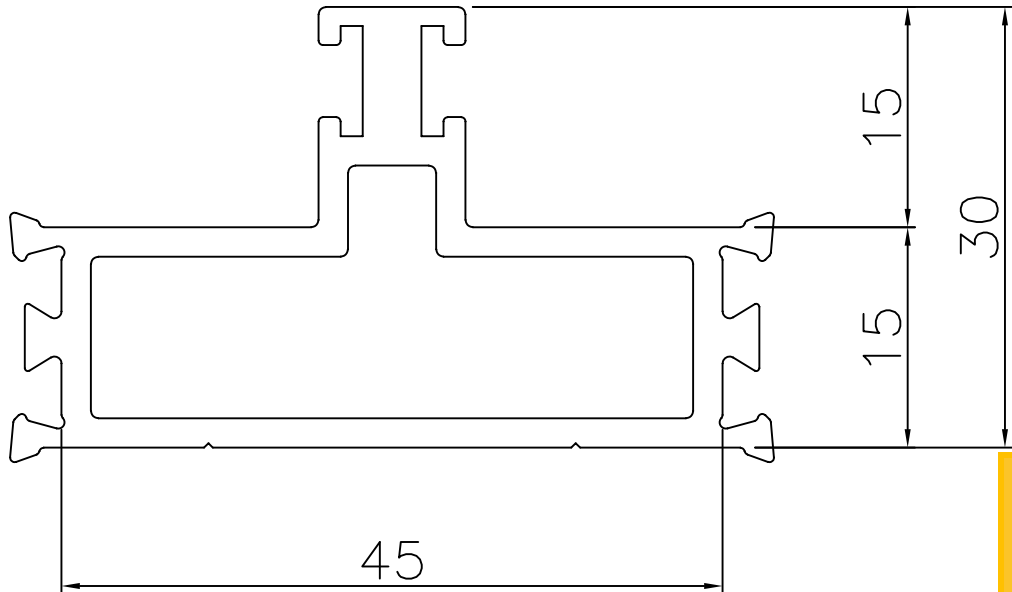

**Intertek**  
Total Quality Assured.

Report #: L1411-116-45  
Date: 7/8/2020  
Verified by: *[Signature]*

Material : Painted Aluminum Alloy

no.09

# Frame Sill Attach

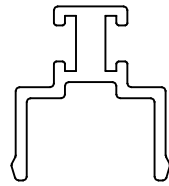

ACTUAL SIZE

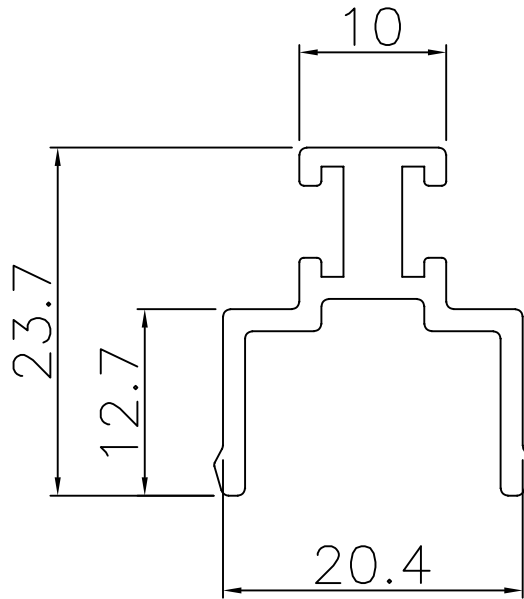

Material : Painted Aluminum Alloy

**intertek**  
Total Quality Assured.

Report #:	L1411-116-45
Date:	7/8/2020
Verified by:	

# no.10 Frame Cover1

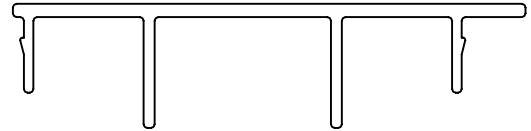

ACTUAL SIZE

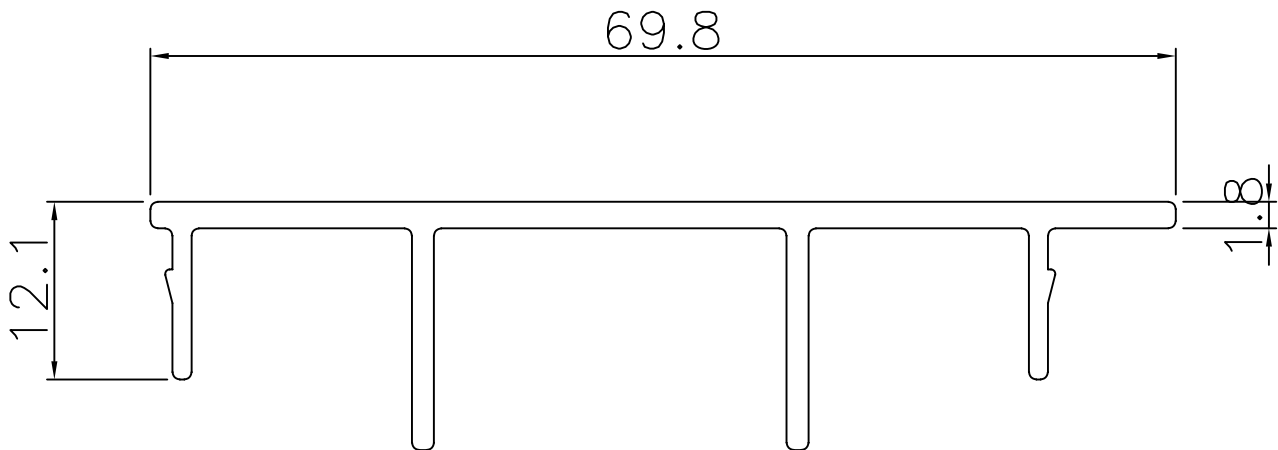

Material : Painted Aluminum Alloy

**Intertek**  
Total Quality Assured.

Report #:	11411-116-45
Date:	7/8/2020
Verified by:	

# no.11

## Frame Cover2

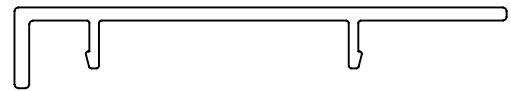

ACTUAL SIZE

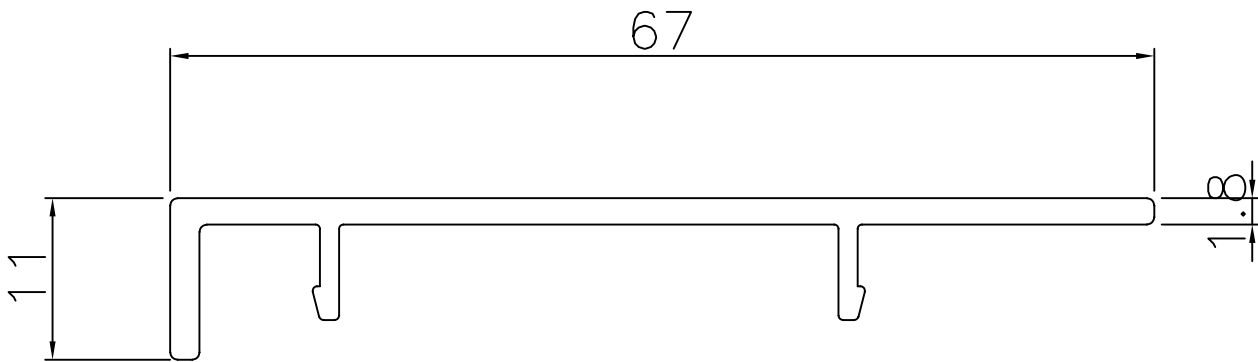

Material : Painted Aluminum Alloy

**intertek**  
Total Quality Assured.

Report #:	L1411-116-45
Date:	7/8/2020
Verified by:	

# no.12

## Vent Bottom IN

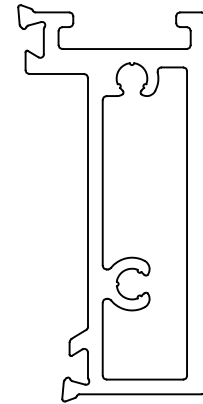
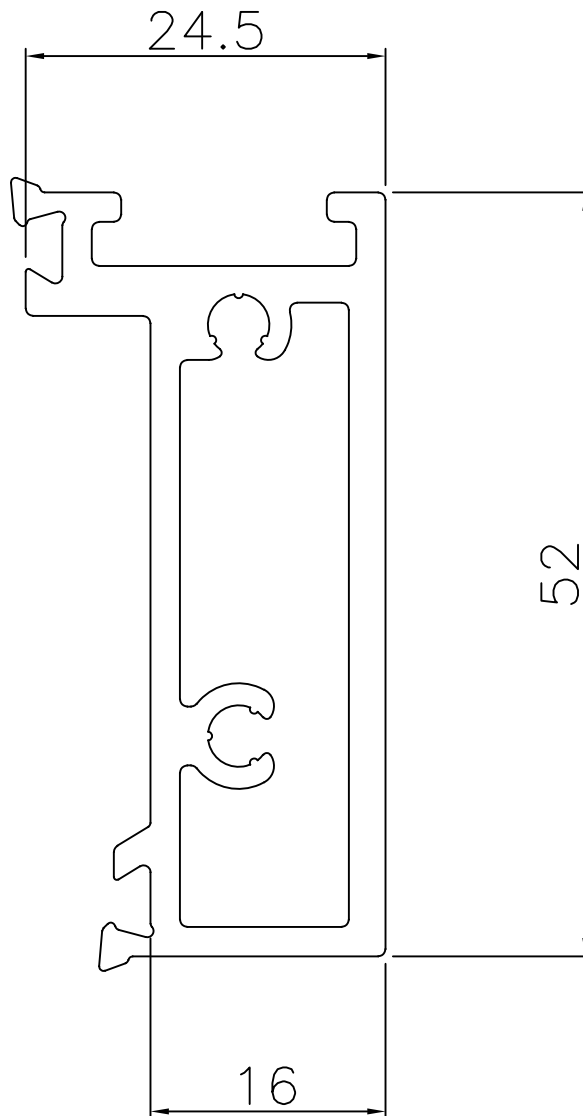

ACTUAL SIZE

Material : Painted Aluminum Alloy

**Intertek**  
Total Quality Assured.

Report #:	L1411-116-45
Date:	7/8/2020
Verified by:	



no.13

Vent Bottom OUT

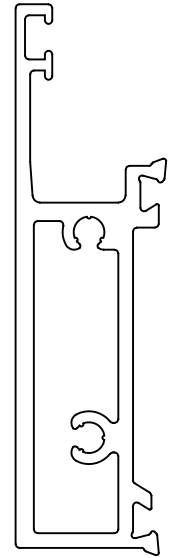
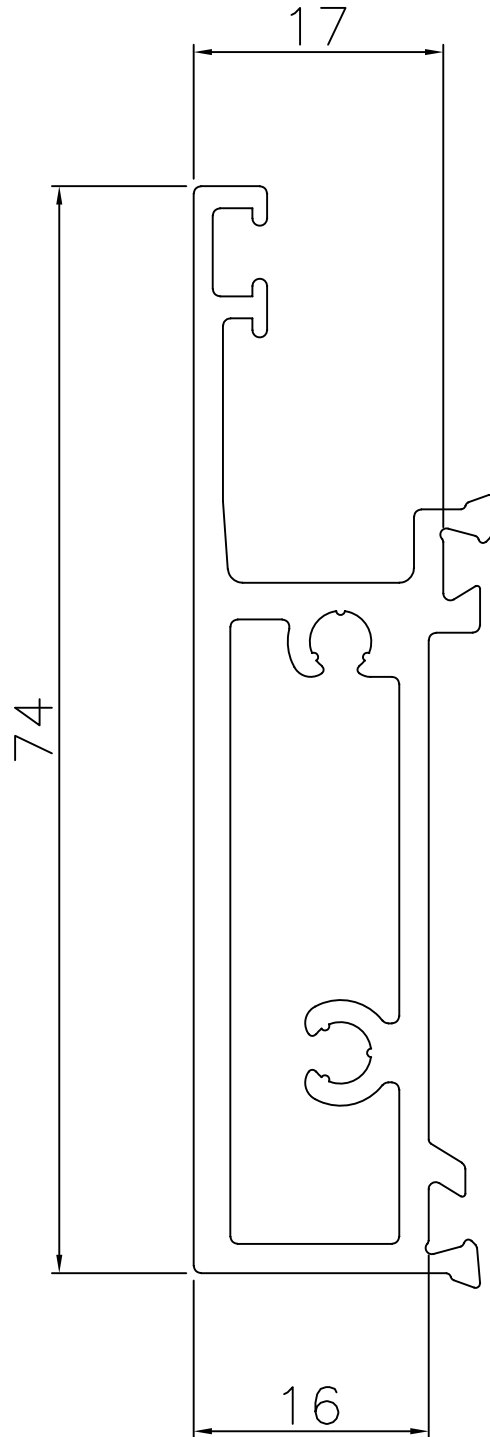

ACTUAL SIZE

Material : Painted Aluminum Alloy

**intertek**  
Total Quality Assured.

Report #:	L1411-116-45
Date:	7/8/2020
Verified by:	

# no.14

## Vent Top IN

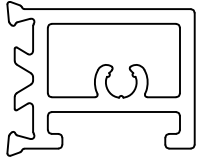

ACTUAL SIZE

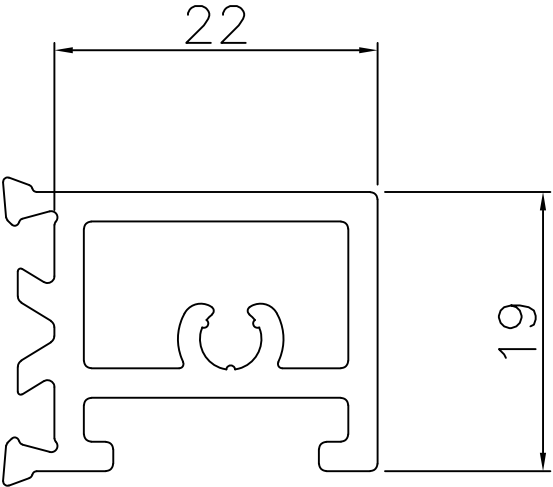

Material : Painted Aluminum Alloy

**intertek**  
Total Quality Assured.

Report #: 11411-116-45  
Date: 7/8/2020  
Verified by: 

# no.15

## Vent Top OUT

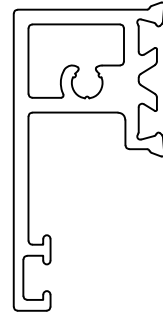
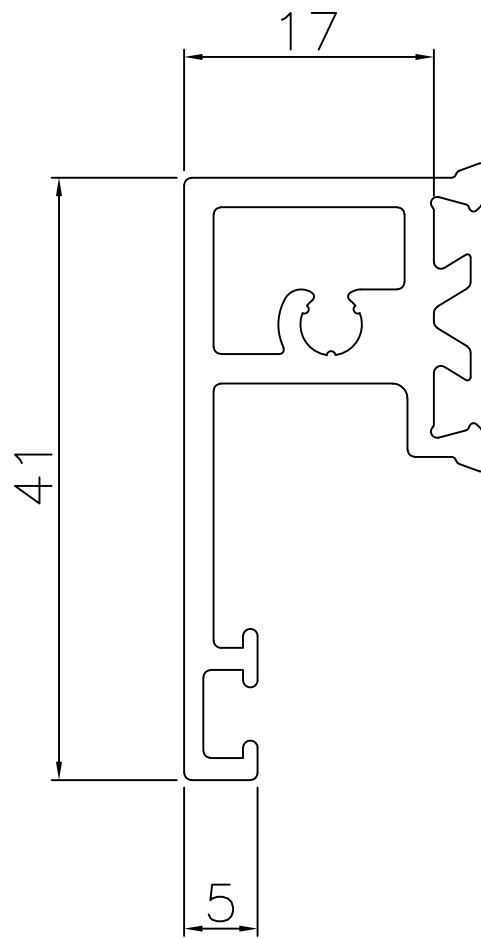

ACTUAL SIZE

Material : Painted Aluminum Alloy

**intertek**  
Total Quality Assured.

Report #:	11411-116-45
Date:	7/8/2020
Verified by:	

# no.16 Vent Stile IN

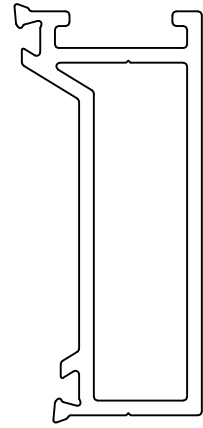
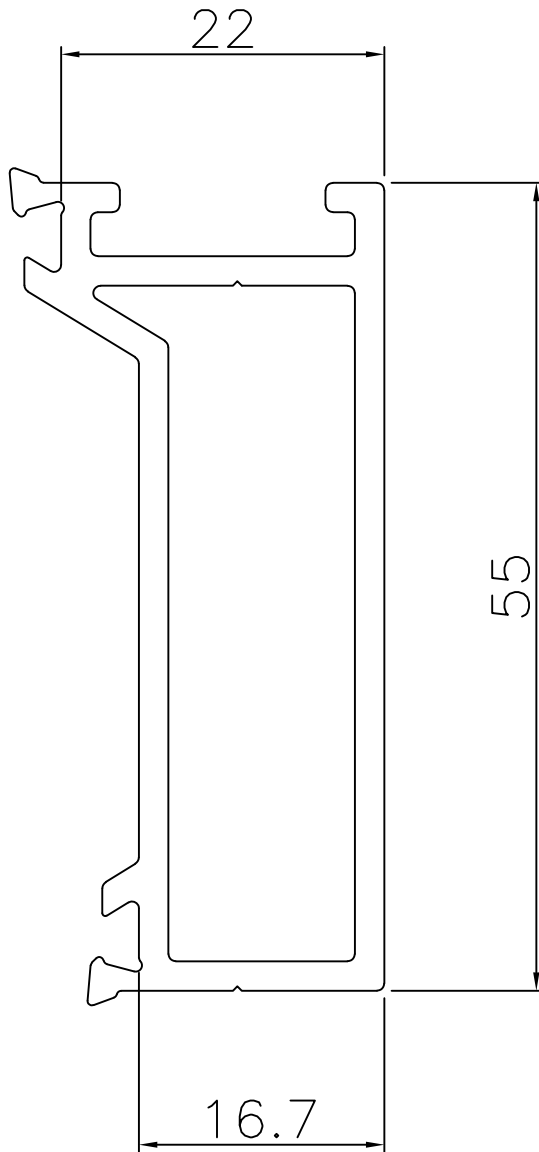

ACTUAL SIZE

Material : Painted Aluminum Alloy

**Intertek**  
Total Quality Assured.

Report #:	L1411-116-45
Date:	7/8/2020
Verified by:	

# no.17 Vent Stile OUT

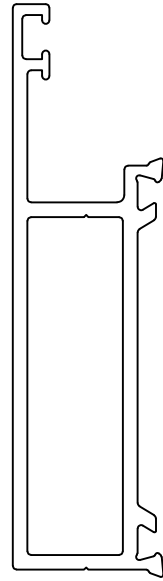
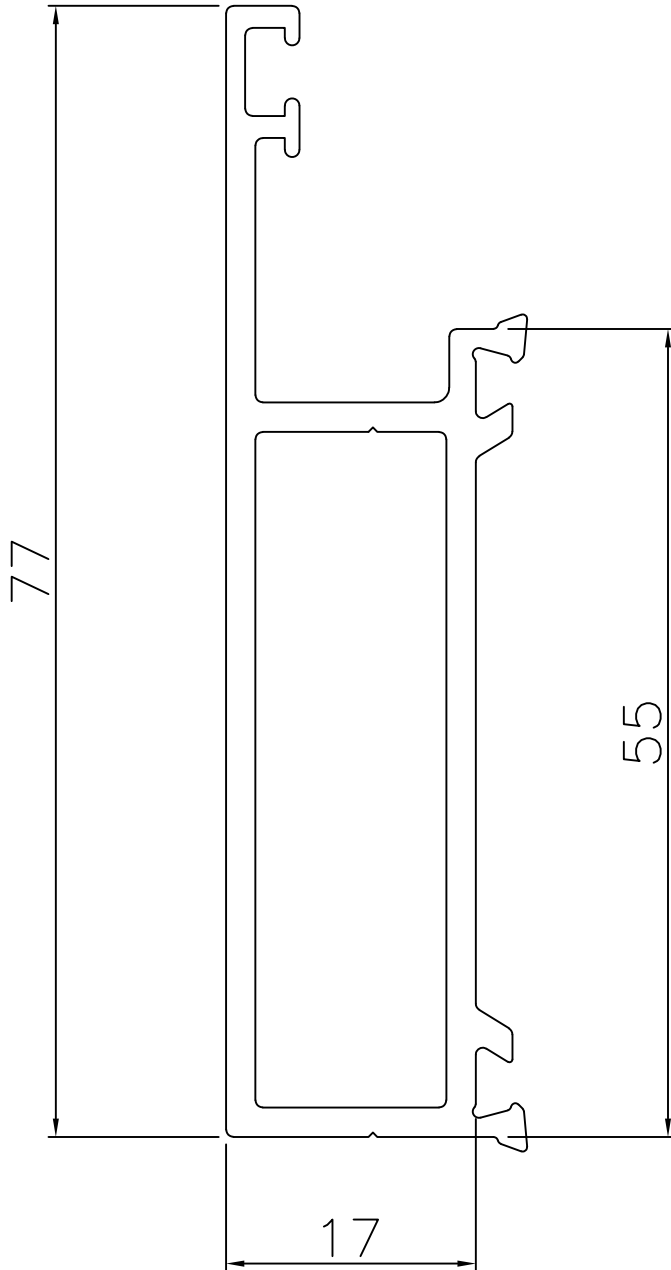

ACTUAL SIZE

Material : Painted Aluminum Alloy

**Intertek**  
Total Quality Assured.

Report #: 11411-116-45  
Date: 7/8/2020  
Verified by: *[Signature]*

no.18

# Vent Interlock IN

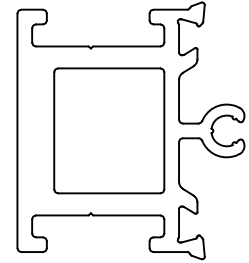

ACTUAL SIZE

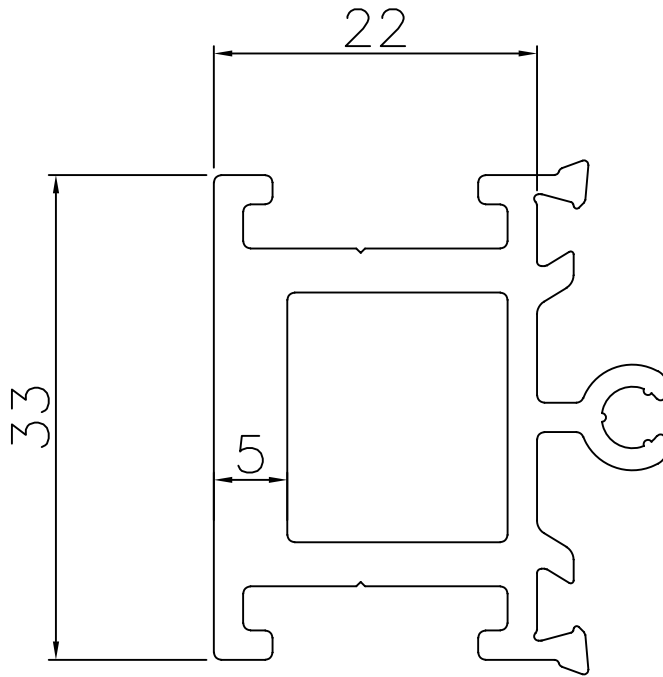

Material : Painted Aluminum Alloy

**intertek**  
Total Quality Assured.

Report #:	L1411-116-45
Date:	7/8/2020
Verified by:	

no.19

Vent Interlock OUT1

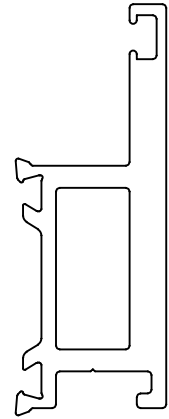
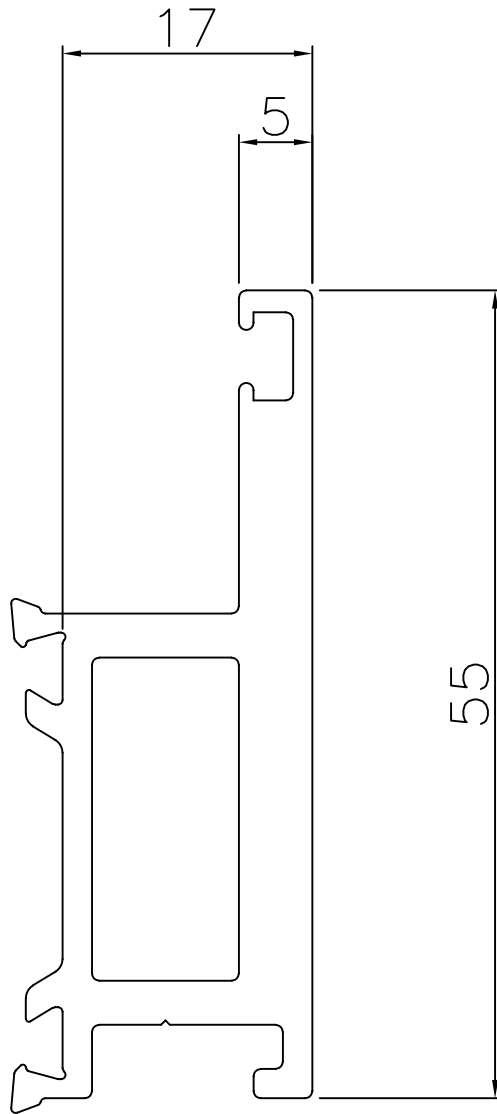

ACTUAL SIZE

Material : Painted Aluminum Alloy

**intertek**  
Total Quality Assured.

Report #:	L1411-116-45
Date:	7/8/2020
Verified by:	

no.20

Vent Interlock OUT2

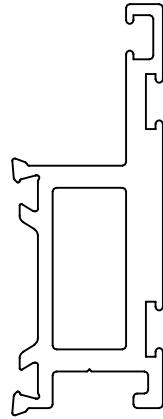
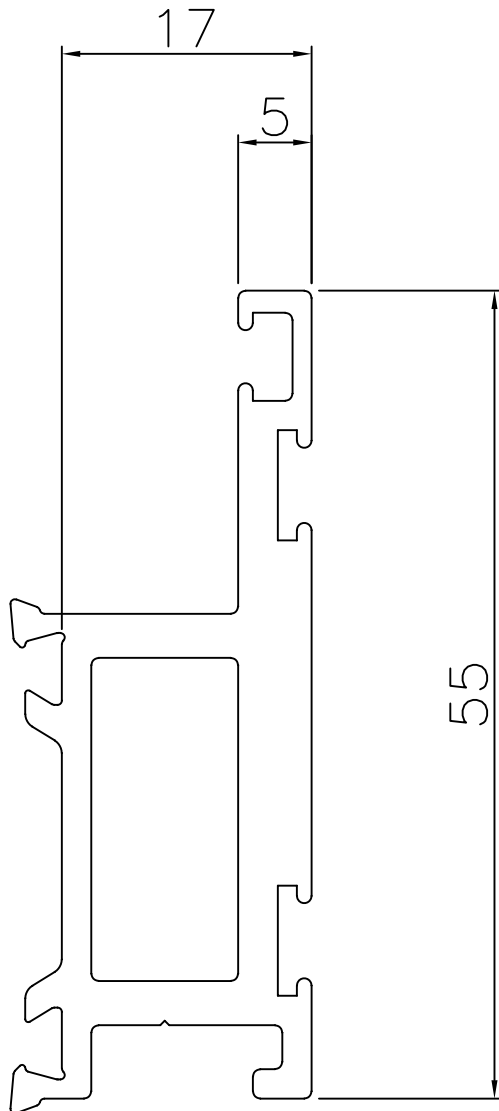

ACTUAL SIZE

Material : Painted Aluminum Alloy

**Intertek**  
Total Quality Assured.

Report #:	L1411-116-45
Date:	7/8/2020
Verified by:	



**Intertek**  
Total Quality Assured.

Report #: L1411-116-45  
Date: 7/8/2020  
Verified by: 

no.21

# Vent Interlock Cover

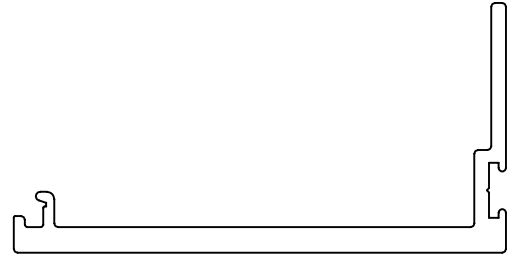

ACTUAL SIZE

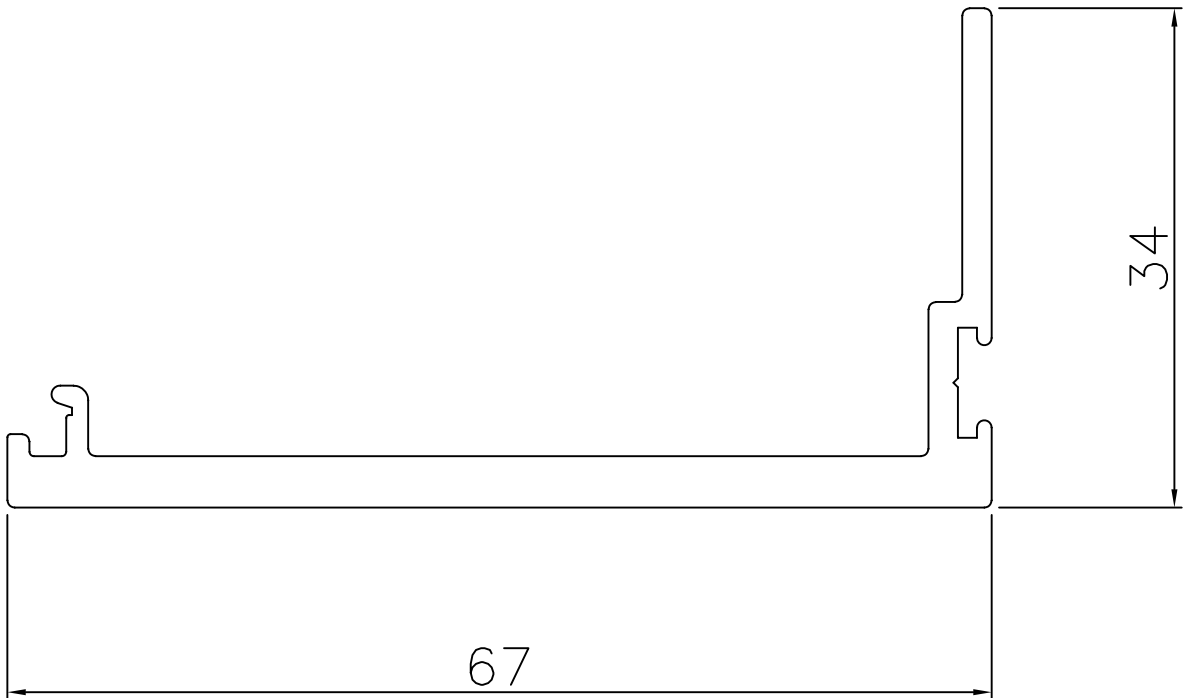

Material : Painted Aluminum Alloy

# no.22

## VENT Bottom Attach

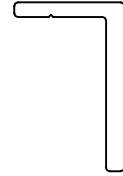

ACTUAL SIZE

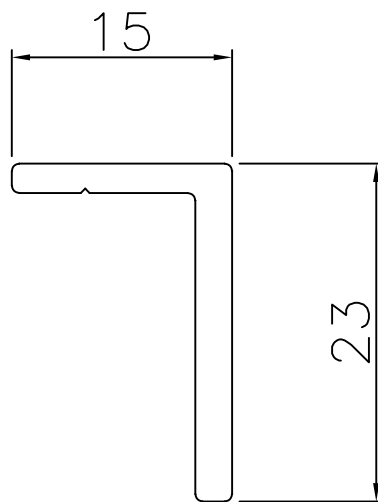

Material : Painted Aluminum Alloy

**intertek**  
Total Quality Assured.

Report #:	11411-116-45
Date:	7/8/2020
Verified by:	

# no.23 Vent Bead

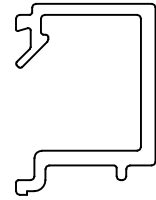

ACTUAL SIZE

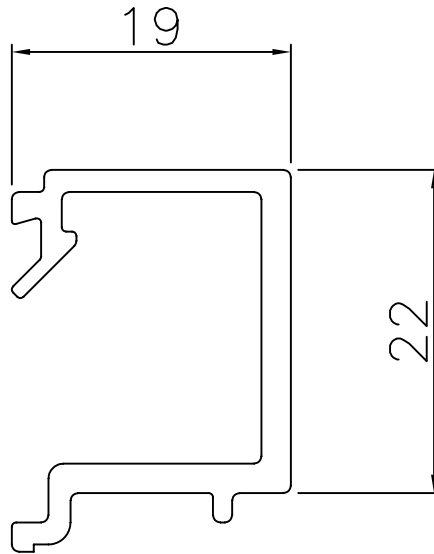

Material : EPDM / EPDM SPONGE

**intertek**  
Total Quality Assured.

Report #:	L1411-116-45
Date:	7/8/2020
Verified by:	

no.24

# Frame Insulation Bar 13mm



ACTUAL SIZE

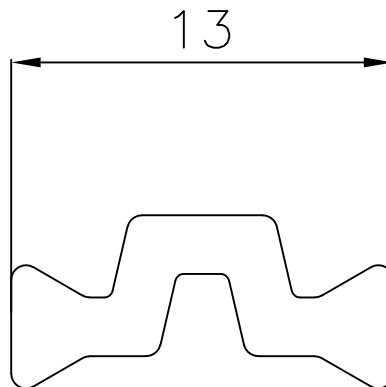

Material : Polyamide 6.6 with 25% glass fiber

**intertek**  
Total Quality Assured.

Report #:	11411-116-45
Date:	7/8/2020
Verified by:	

no.25

Frame Insulation Bar 18mm

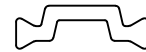

ACTUAL SIZE

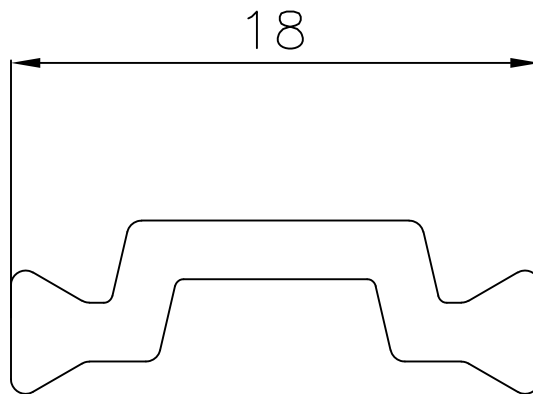

Material : Polyamide 6.6 with 25% glass fiber

**intertek**  
Total Quality Assured.

Report #:	11411-116-45
Date:	7/8/2020
Verified by:	

no.26

Frame Insulation Bar 23.3mm

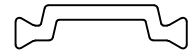

ACTUAL SIZE

23.3

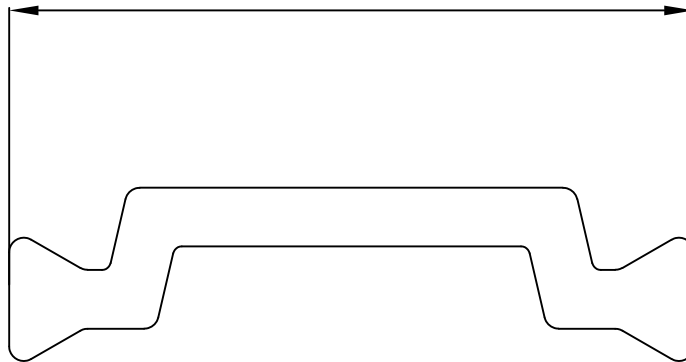

Material : Polyamide 6.6 with 25% glass fiber

**intertek**  
Total Quality Assured.

Report #:	L1411-116-45
Date:	7/8/2020
Verified by:	

no.27

# Frame Insulation Bar 25mm

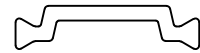

ACTUAL SIZE

25

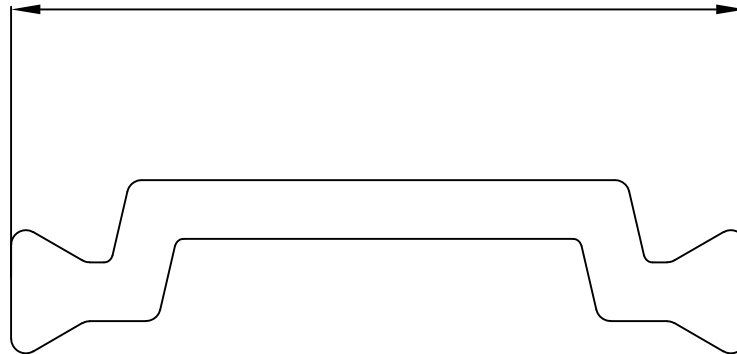

Material : Polyamide 6.6 with 25% glass fiber

**intertek**  
Total Quality Assured.

Report #:	L1411-116-45
Date:	7/8/2020
Verified by:	

no.28

# Frame Sill Attach

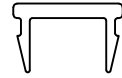

ACTUAL SIZE

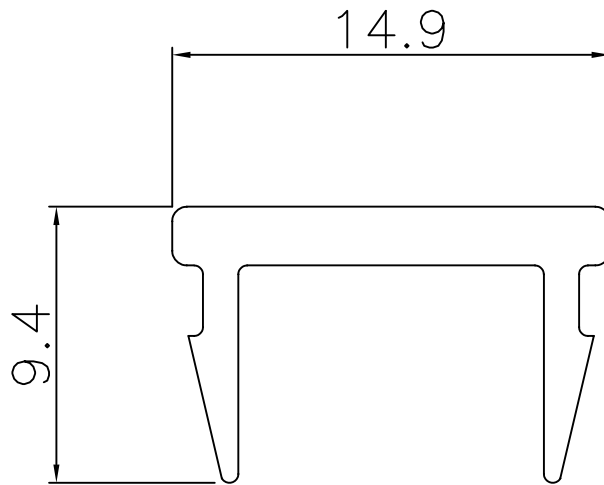

Material : PVC

**intertek**  
Total Quality Assured.

Report #:	11411-116-45
Date:	7/8/2020
Verified by:	



no.29

# Interlock Cover Attach

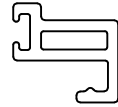

ACTUAL SIZE

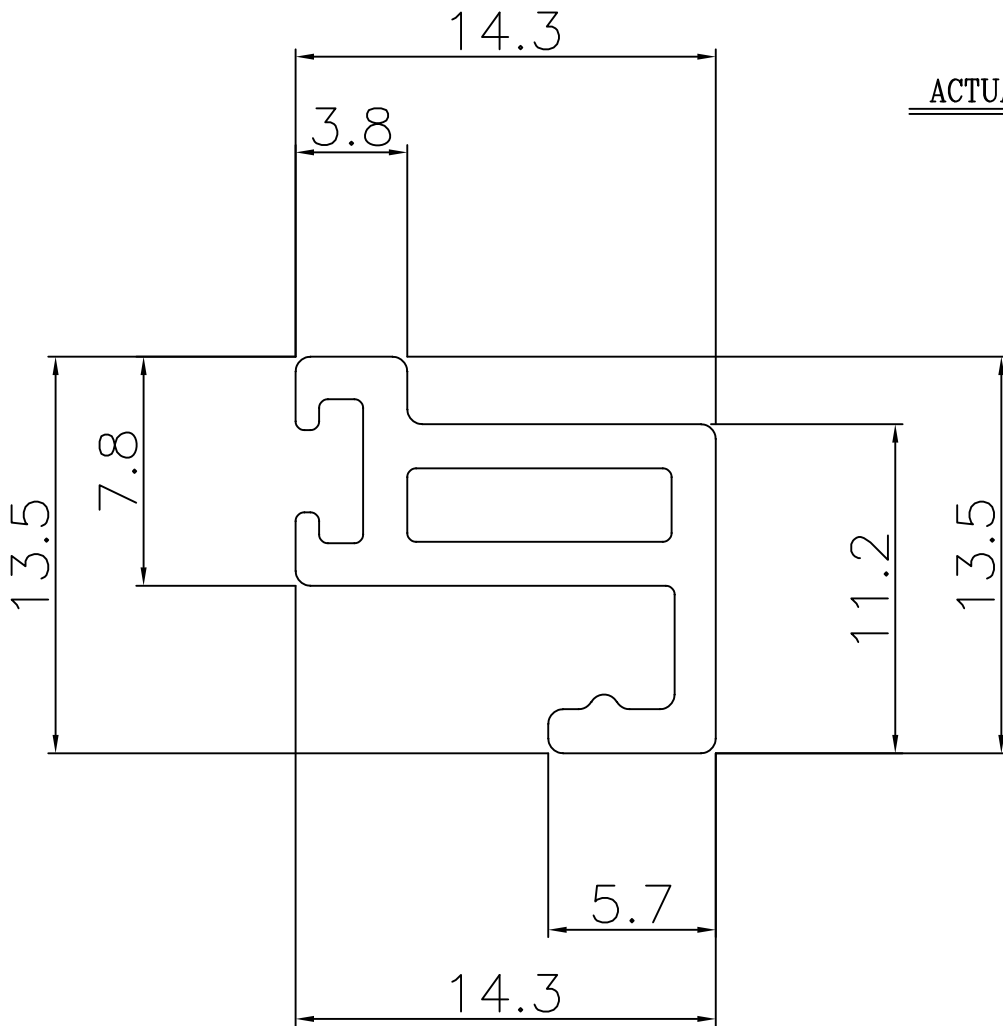

Material : PVC

**intertek**  
Total Quality Assured.

Report #: 11411-116-45  
Date: 7/8/2020  
Verified by: 

no.30

# Interlock Cover Gasket

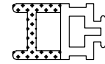

ACTUAL SIZE

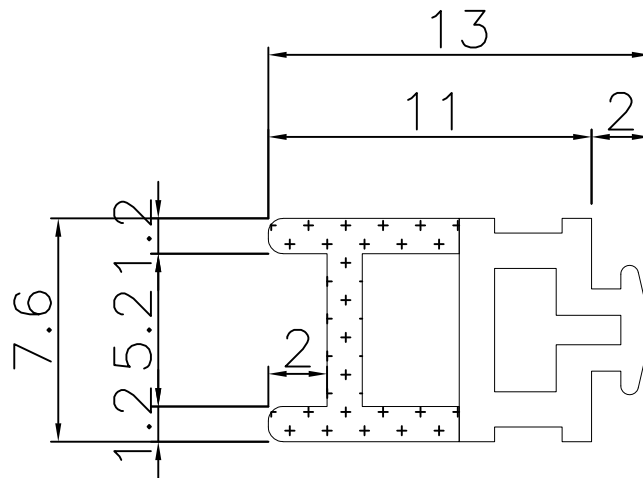

Material : EPDM / EPDM SPONGE

**intertek**  
Total Quality Assured.

Report #: 11411-116-45  
Date: 7/8/2020  
Verified by:

# no.31

## Inside Glazing Gasket



ACTUAL SIZE

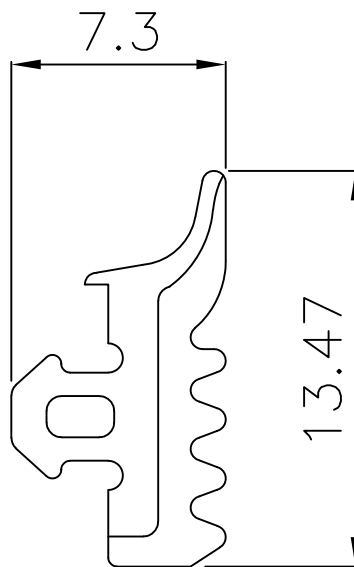

Material : EPDM / EPDM SPONGE

**intertek**  
Total Quality Assured.

Report #:	L1411-116-45
Date:	7/8/2020
Verified by:	

no.32  
Outside Glazing Gasket



ACTUAL SIZE

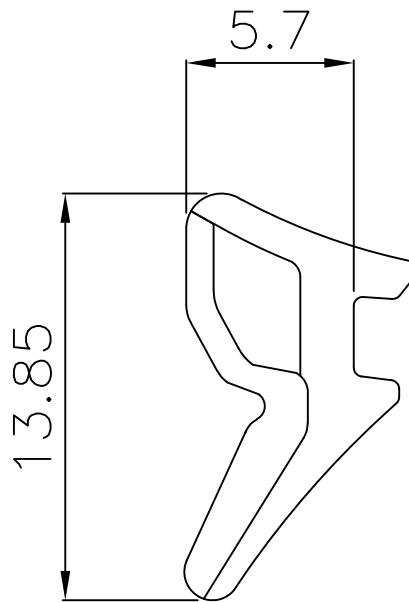

Material : EPDM / EPDM SPONGE

**intertek**  
Total Quality Assured.

Report #:	11411-116-45
Date:	7/8/2020
Verified by:	

no.33

# Glass Insulation Pad



ACTUAL SIZE

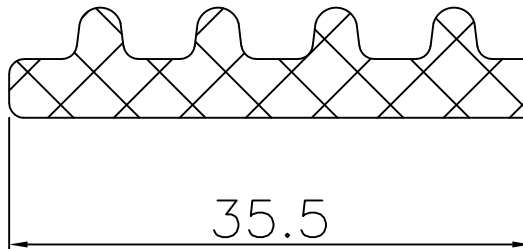

Material : Polyurethane Foam

**intertek**  
Total Quality Assured.

Report #:	L1411-116-45
Date:	7/8/2020
Verified by:	

# no.34

## Frame Sill Rail



ACTUAL SIZE

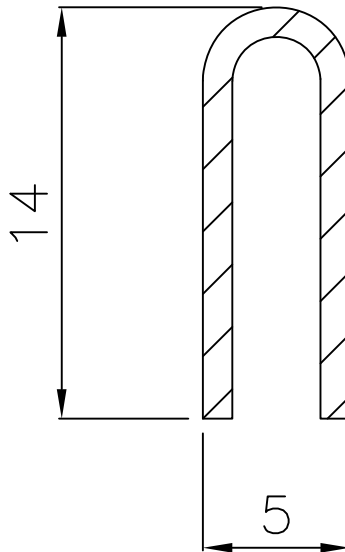

Material : Stainless Steel

**intertek**  
Total Quality Assured.

Report #:	11411-116-45
Date:	7/8/2020
Verified by:	



Total Quality. Assured.

130 Derry Court  
York, Pennsylvania 17406

Telephone: 717-764-7700  
Facsimile: 717-764-4129  
www.intertek.com/building

**TEST REPORT FOR EAGON WINDOWS & DOORS CO., LTD.**

Report No: L1411.02-116-45 R0 R0

Date: 09/03/21

**SECTION 8**

**REVISION LOG**

REVISION #	DATE	PAGES	REVISION
.01R0	07/08/20	N/A	Original report issued to customer.
.02R0	09/03/21	N/A	Add Options #21-40