

ESS 70 SD MT POCKET_Vent assembly manual

1) Assemble the vents with screws then seal the corners and fix the hole cap.

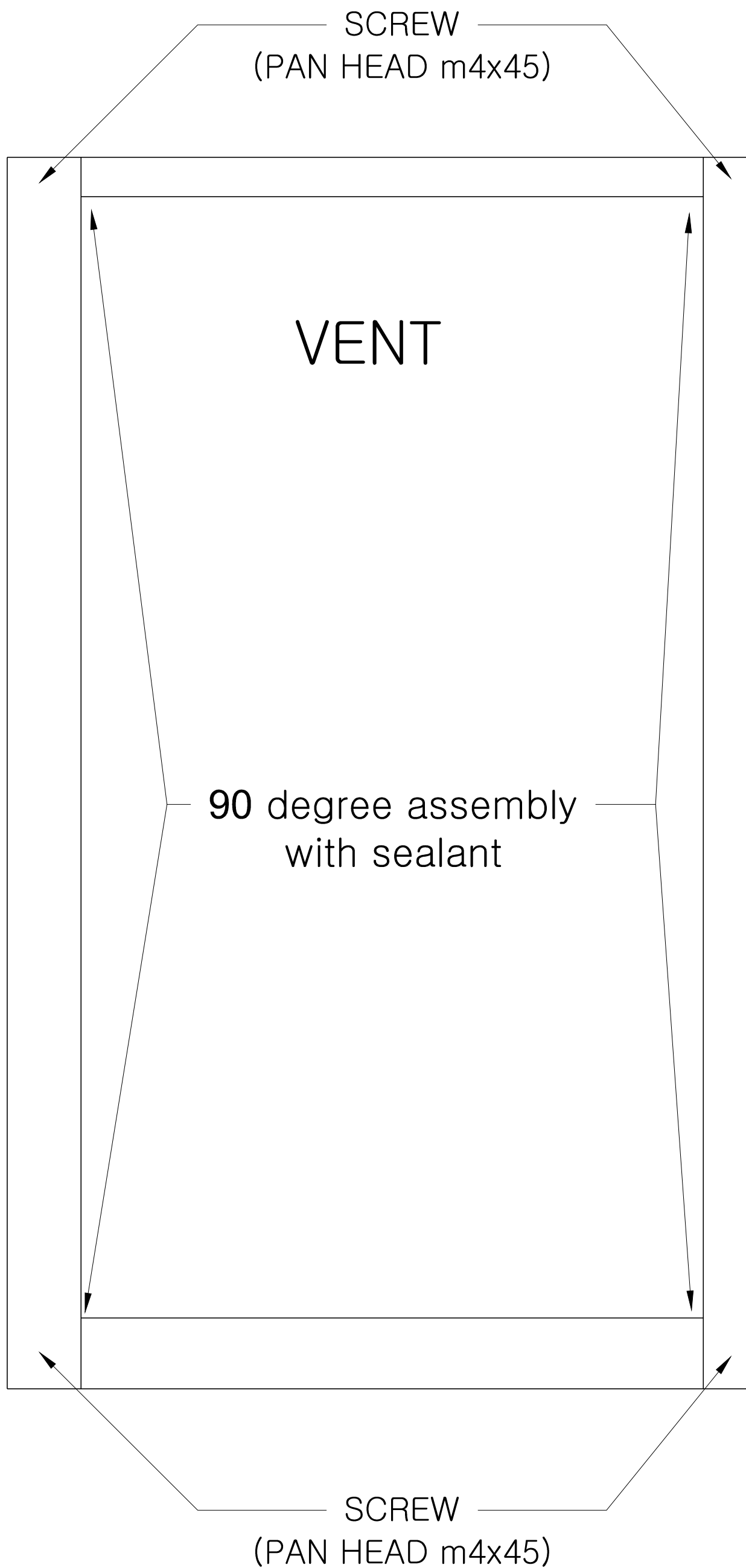

ESS 70 SD MT POCKET_Vent assembly manual

2) Fix the vents interlock cover with screws, then insert the gasket(E70 G01) and 7x7 mohair.

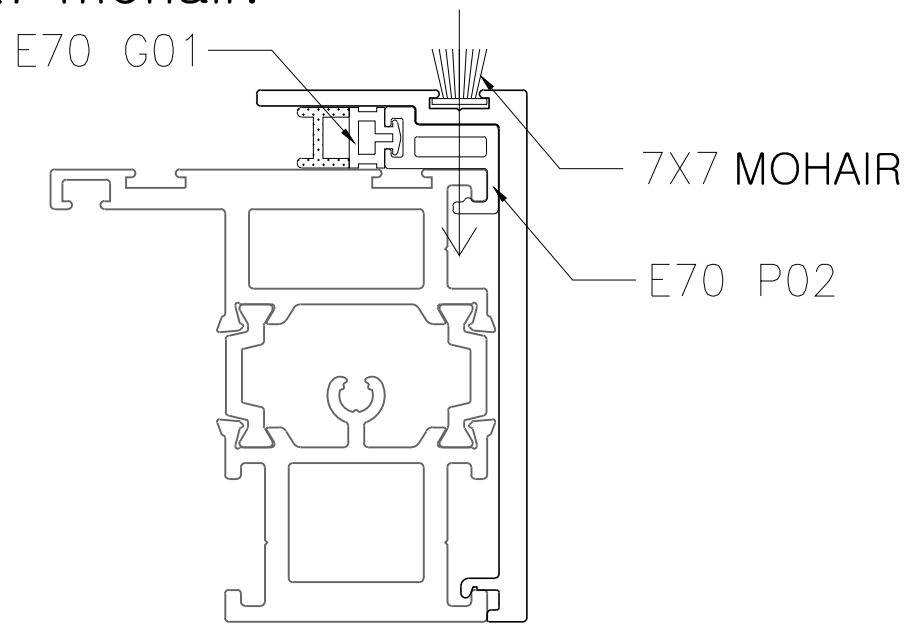

3) Insert 7x15 mohair for 30mm from the top.

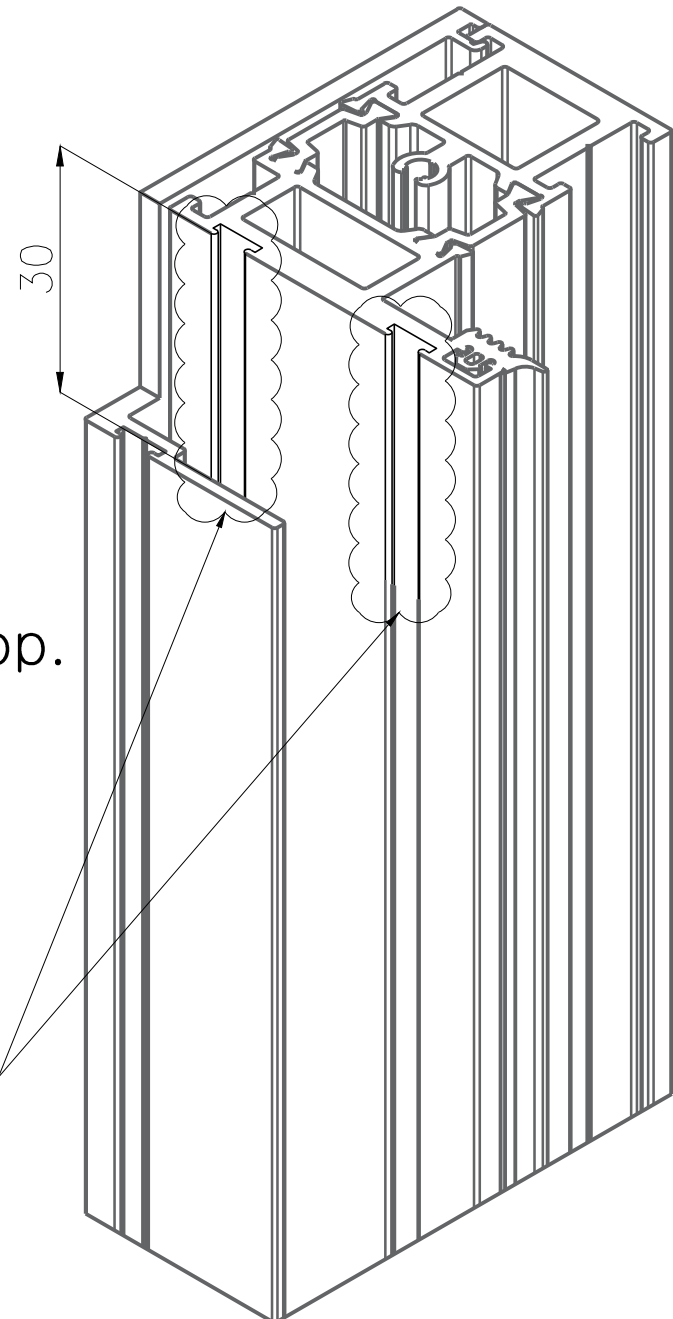
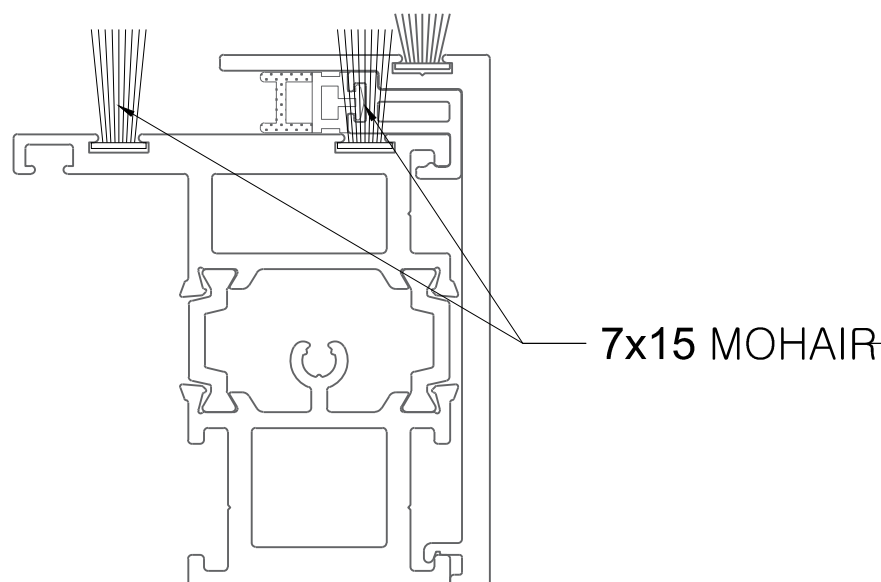

* Follow the direction below.

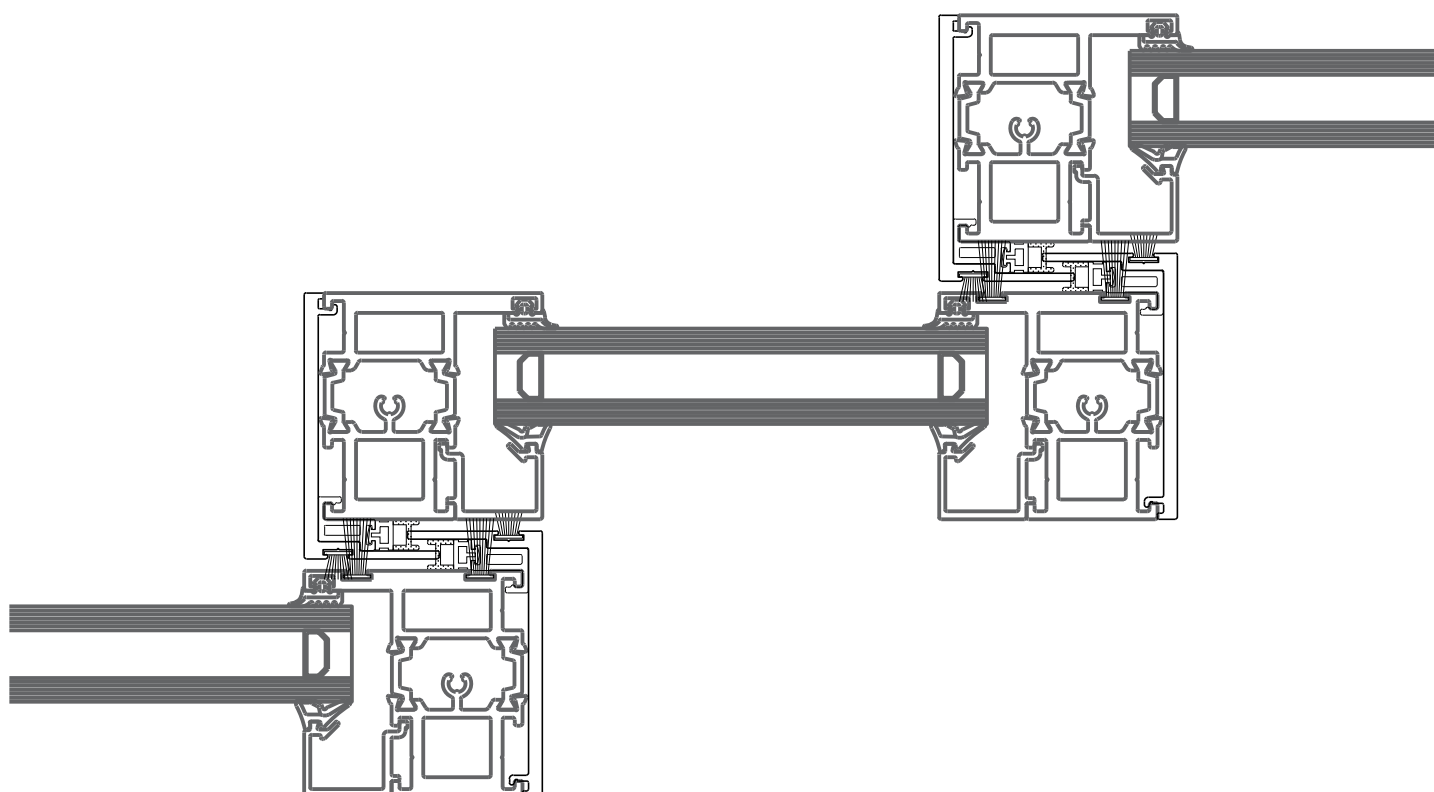

4) Assembly VENT1 – Bottom attachment(E70 V07), Bottom cap(E70 ICL)

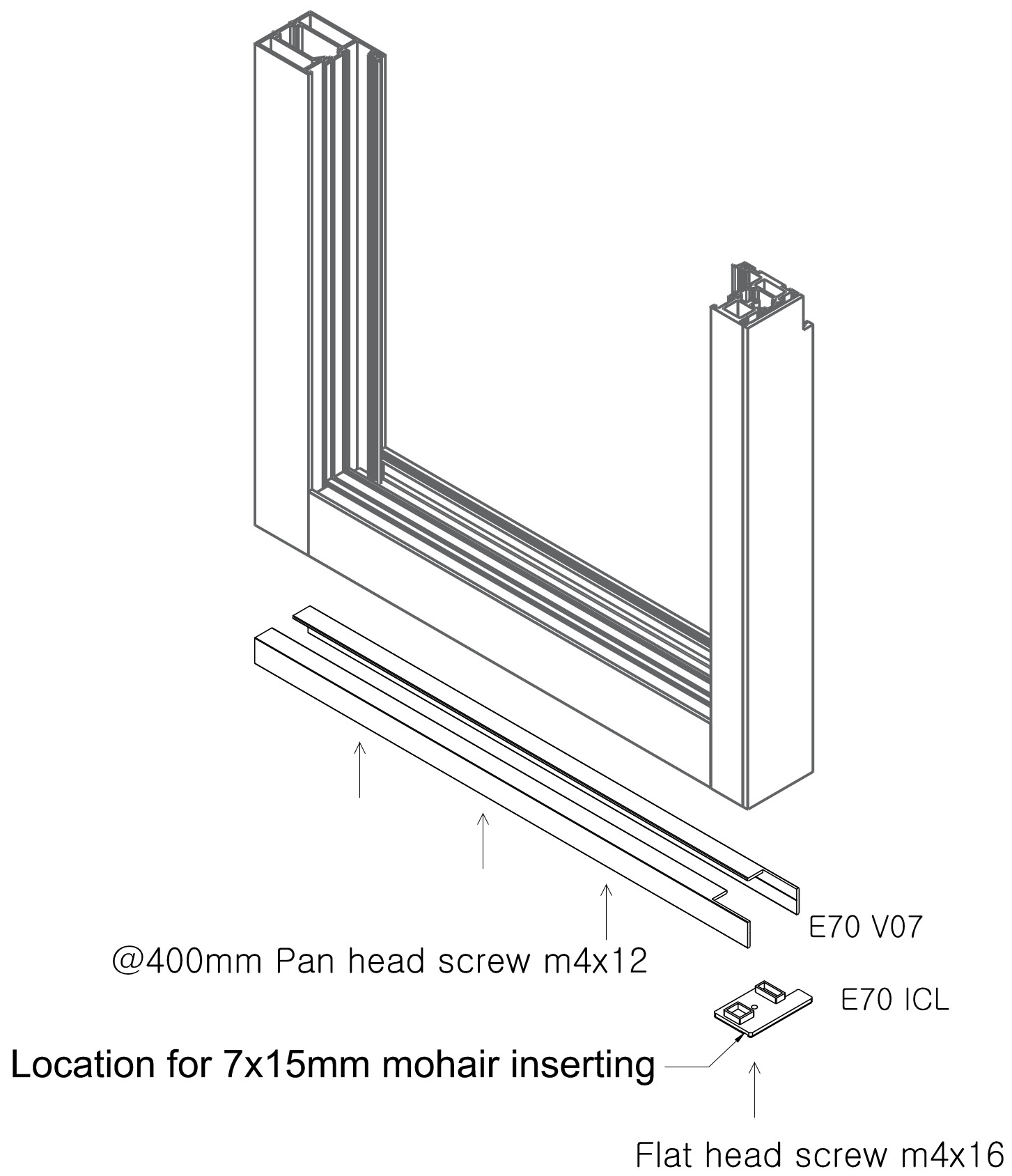

ESS 70 SD MT POCKET_Vent assembly manual

6) Assembly VENT3 – Bottom attachment(E70 V07), Bottom cap(E70 ICL)

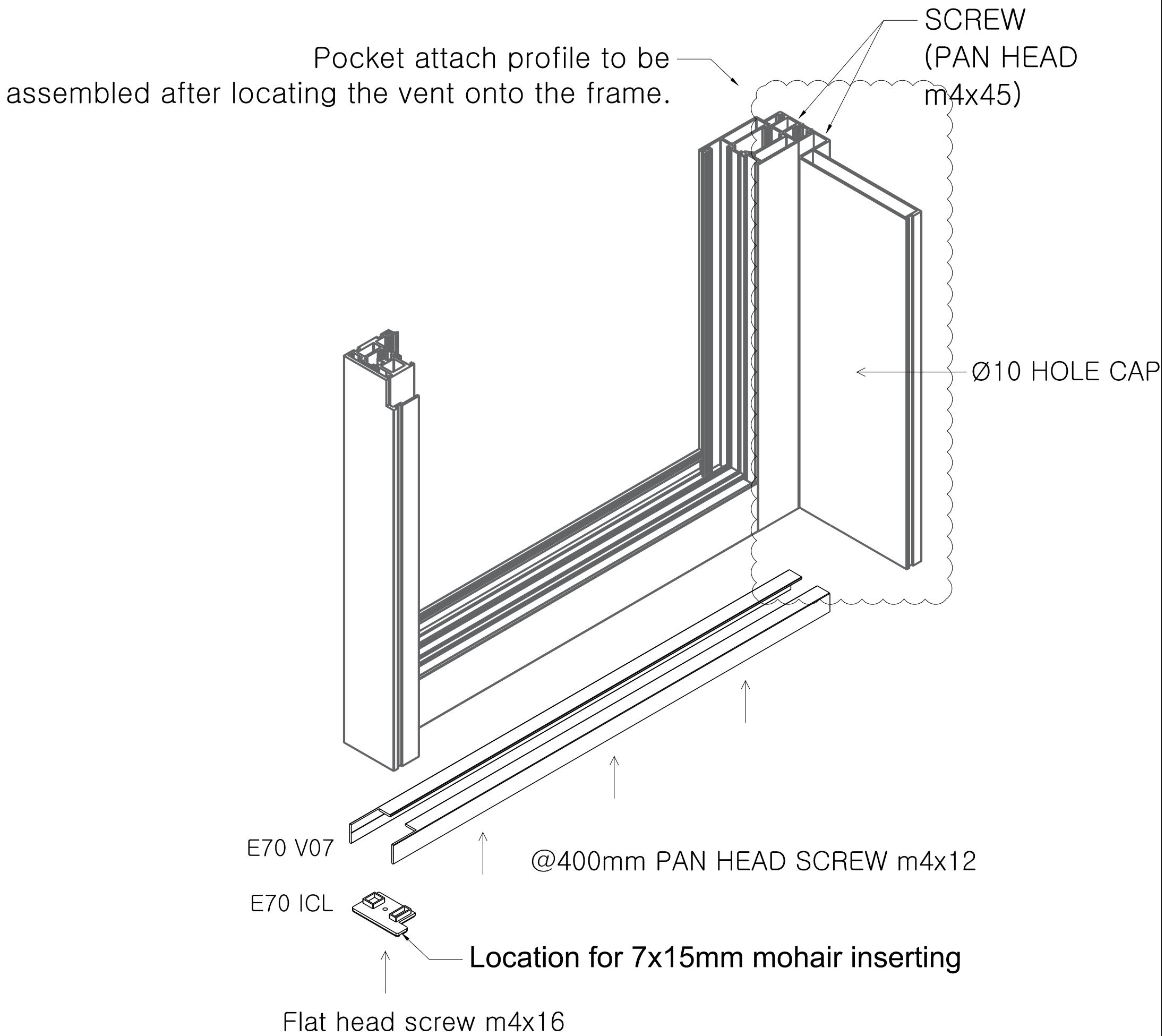

ESS 70 SD MT POCKET_Vent assembly manual

Extra) Al sleeve of head and sill

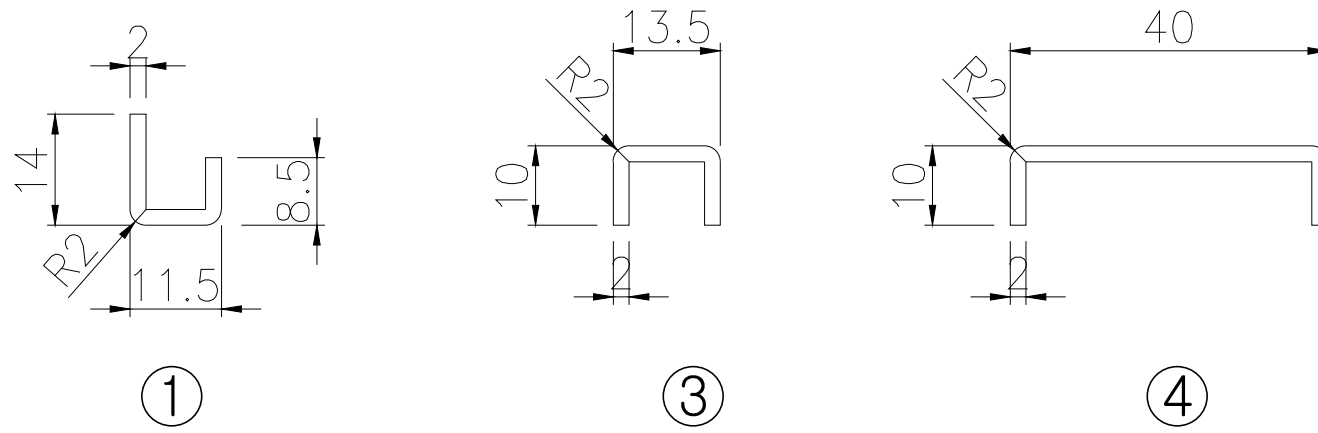

Length: 200mm

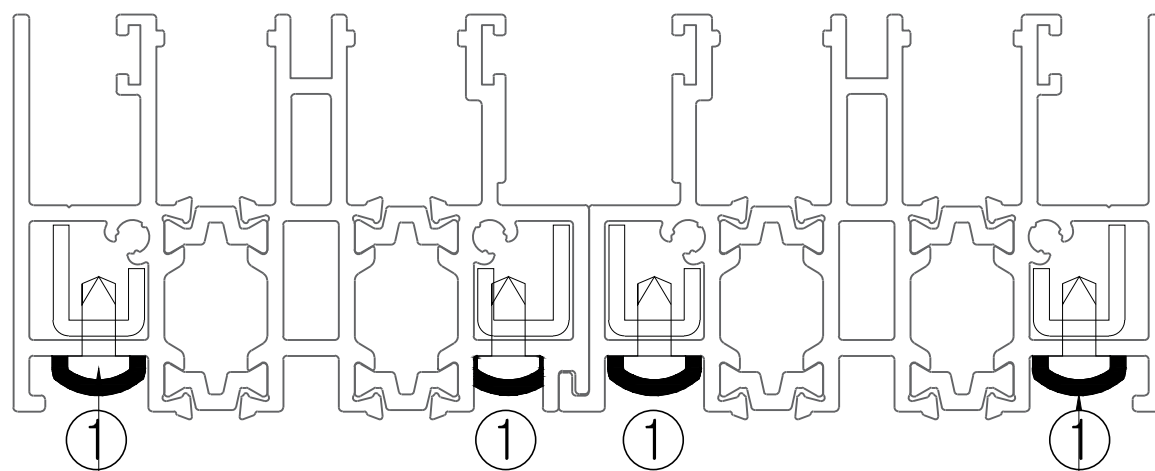
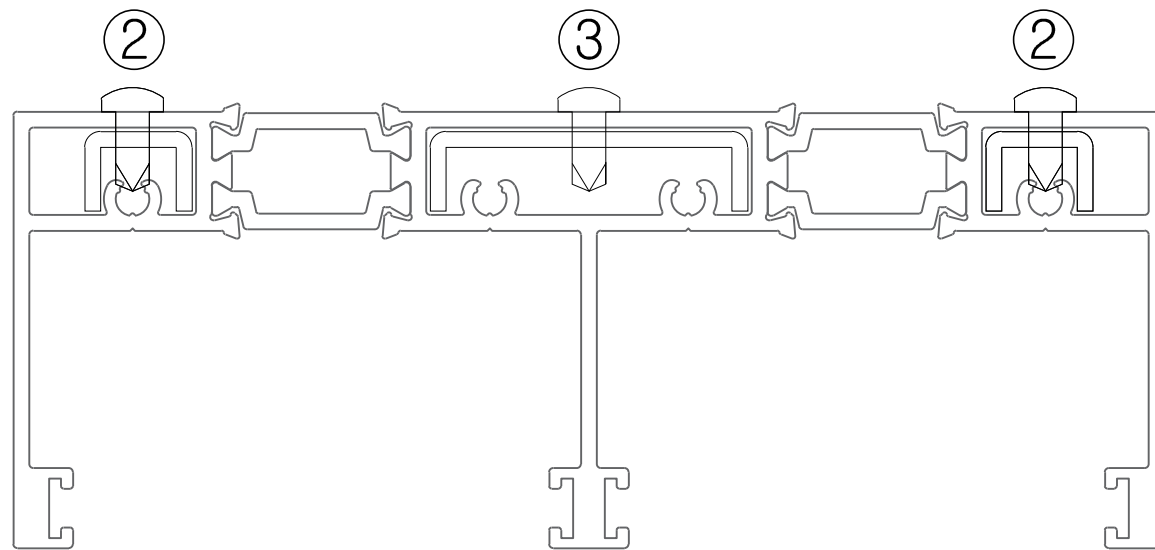

①

①

①

①

Sealanting

Pan head self drilling screw #8(4.2mm)